

RS24 Multi-Section Skylight System

under/over seam clip double diverter

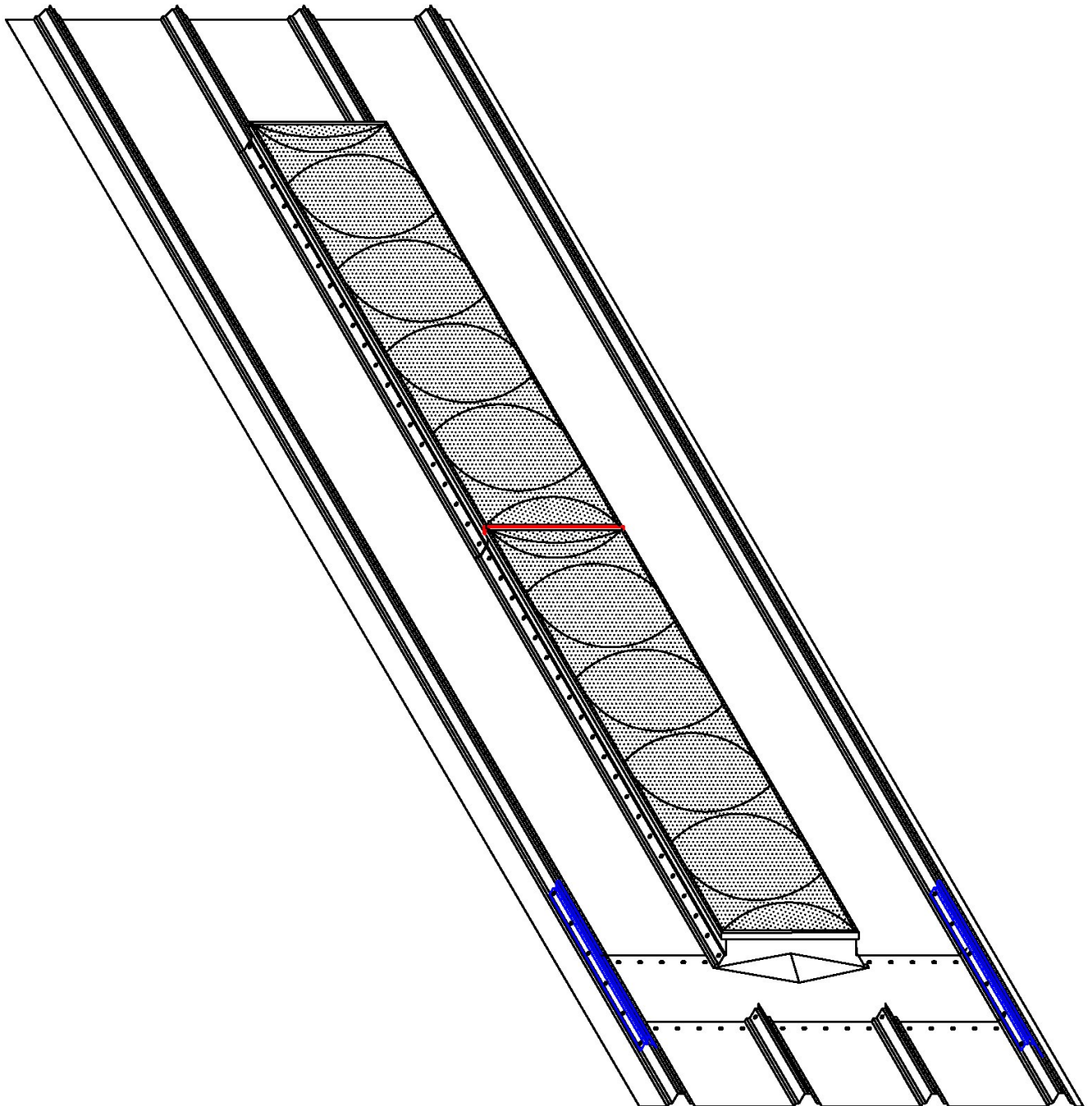

Questions or Need Assistance? 800-423-1619



FIGURE 1: CROSS SECTION

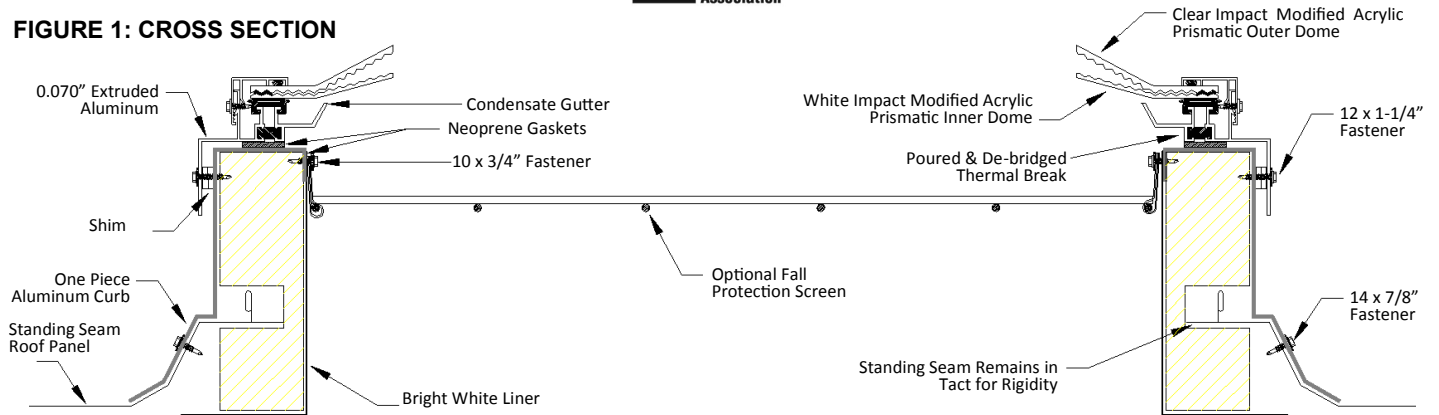
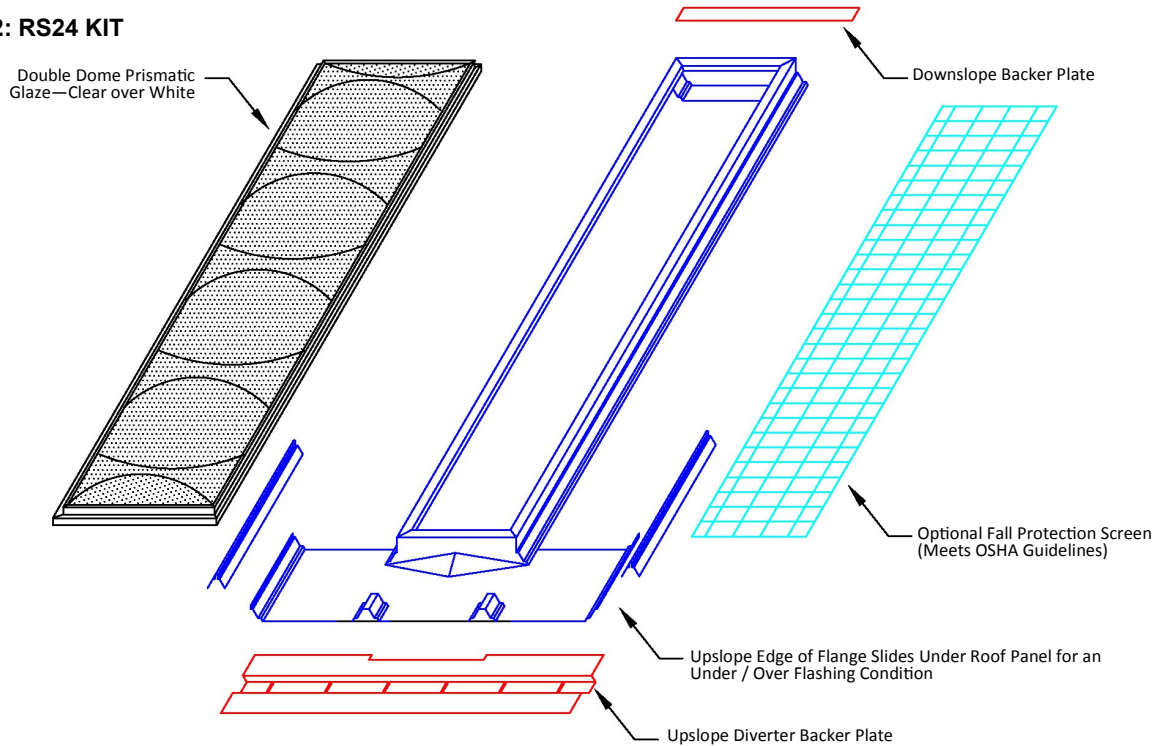

FIGURE 2: RS24 KIT



CONSTRUCTION

- 0.080" Aluminum Under/Over Fully Welded & Assembled Base
- 0.070" Extruded Aluminum Thermally Broken Skylight Frame
- 2" Rigid Vertical Insulation with Bright White Metal Liner
- 1/8" x 1" Neoprene Gasket Seals Skylight Frame
- Clear, 100% Impact Modified Acrylic Prismatic 0.177" Outer Dome
- White, 100% Impact Modified Acrylic Prismatic 0.118" Inner Dome
- 2-1/2" Triple Bead Mastic Tape, Polyurethane Sealant
- #5 Tek Shoulder Screws
- Long-Life Self Drillers w/ Washers: 12-14 x 1-1/4" & 14 x 7/8"
- Long-Life Self Drillers w/o Washers: 12 x 1-1/4" & 10 x 3/4"

PERFORMANCE

- 70% Visible Light Transmittance with 100% Haze Factor
- 0.50 Solar Heat Gain Coefficient
- 0.65 U Factor or 1.54 R Value

OPTIONS

- 4" x 4" x 3/16" galvanized steel fall protection screen
- RS24 Custom Length—Increments of 5': _____
- Panel Offset Height: 3/8", 1-3/8", Custom _____
- Liner Height: 5-7/8", Custom _____
- Liner Base: 3", Custom _____

Customer		Date		Model		Quantity	
Project Name		Roof Panel		Panel Offset Height	3/8"	1-3/8"	



FIGURE 1: CROSS SECTION

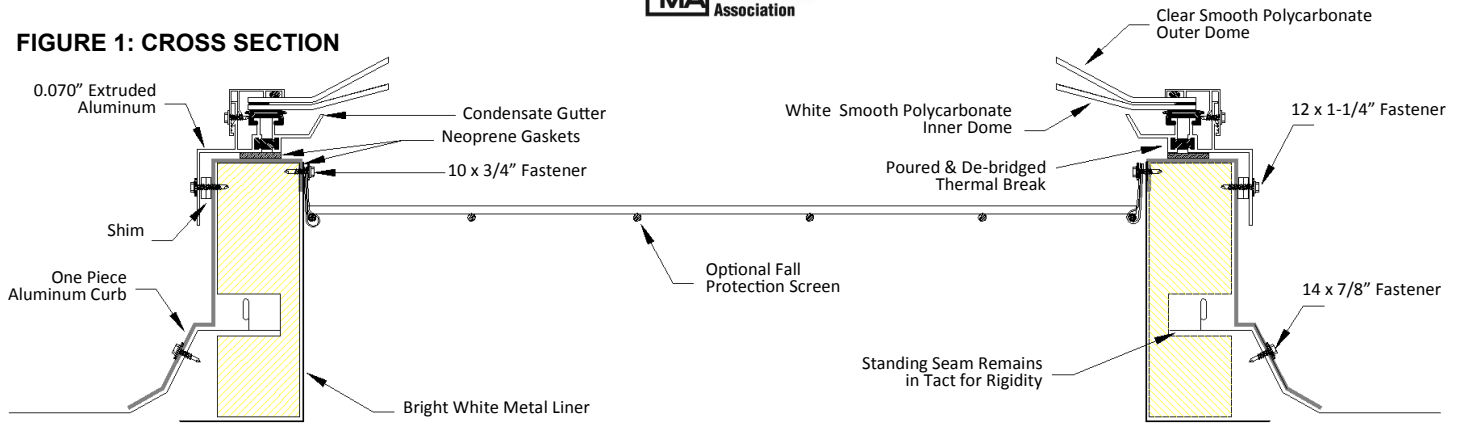
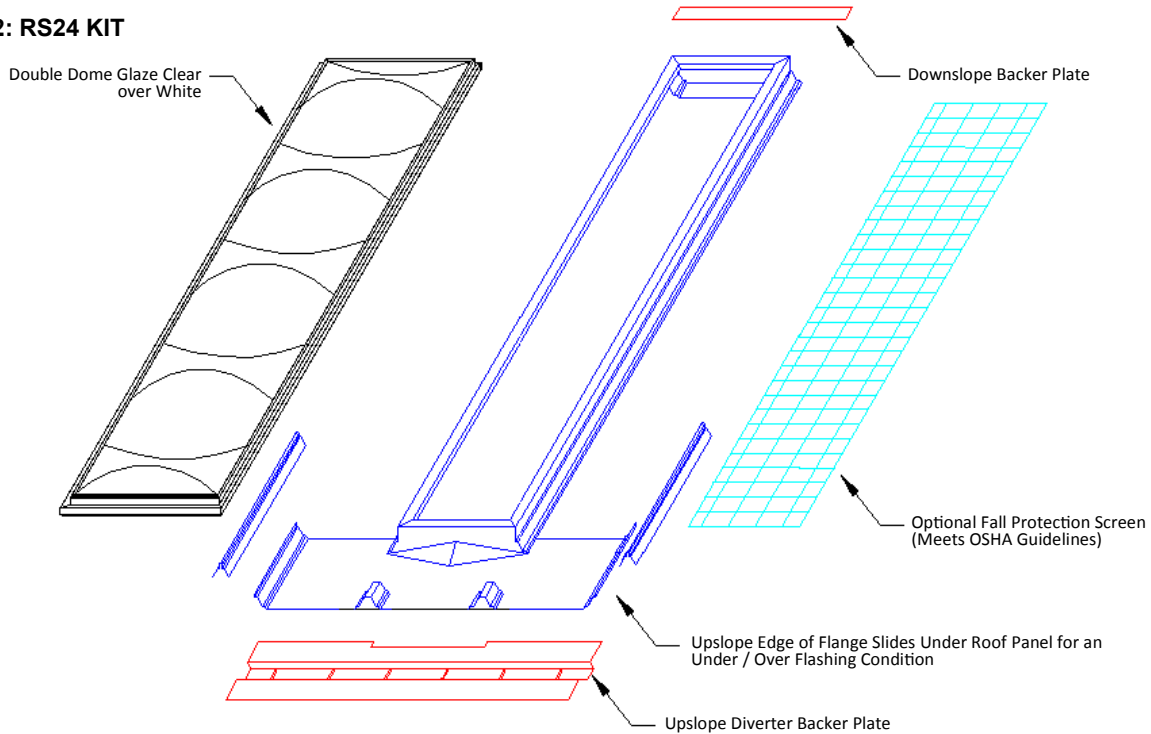

FIGURE 2: RS24 KIT



CONSTRUCTION

- 0.080" Aluminum Under/Over Fully Welded & Assembled Base
- 0.070" Extruded Aluminum Thermally Broken Skylight Frame
- 2" Rigid Vertical Insulation with Bright White Metal Liner
- 1/8" x 1" Neoprene Gasket Seals Skylight Frame
- Clear Smooth Polycarbonate 0.118" Outer Dome
- White Smooth Polycarbonate 0.118" Inner Dome
- 2-1/2" Triple Bead Mastic Tape, Polyurethane Sealant
- #5 Tek Shoulder Screws
- Long-Life Self Drillers w/ Washers: 12-14 x 1-1/4" & 14 x 7/8"
- Long-Life Self Drillers w/o Washers: 12 x 1-1/4" & 10 x 3/4"
- Expansion Joint Covers with 1/4" Flanged Shoulder Spacers

PERFORMANCE

- 60% Visible Light Transmittance with 98% Haze Factor
- 0.26 Solar Heat Gain Coefficient
- 0.70 U Factor or 1.43 R Value
- AAMA/WDMA/CSA 101/I.S.2/A440-08

OPTIONS

- 4" x 4" x 3/16" galvanized steel fall protection screen
- RS24 Custom Length—Increments of 5' _____
- Panel Offset Height: 3/8", 1-3/8", Custom _____
- Liner Height: 5-7/8", Custom _____
- Liner Base: 3", Custom _____
- Miami-Dade County Control Approved _____

Customer		Date		Model		Quantity	
Project Name		Roof Panel		Panel Offset Height	3/8"	1-3/8"	

SKYLIGHT DOMES & SCREENS

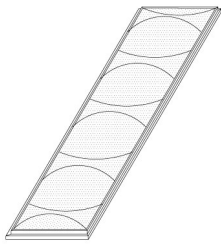

10' Normal Frame

Qty _____

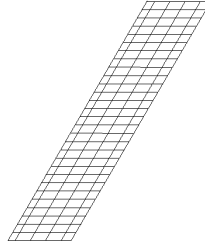

10' Safety Screen

Qty _____

SKYLIGHT CURB SECTIONS

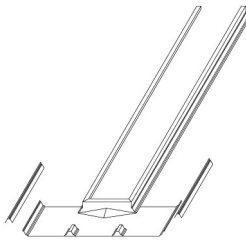

10' Upslope Curb

Qty _____

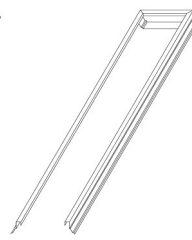

10' Downslope

Qty _____

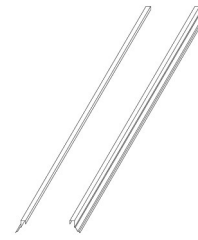

10' Intermediate

Qty _____

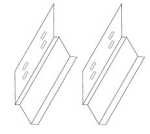

Expansion Joints

Qty _____

CURB INSULATION & LINERS

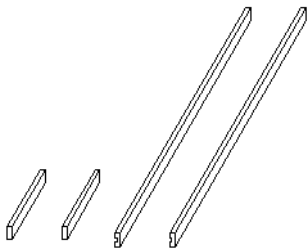

10' Insulation Set

Qty _____

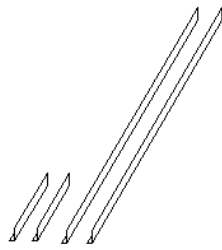

10' Curb Liner Set

Qty _____

BACKER CHANNELS & BATTENS

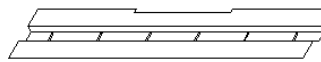

Upslope Backer Channel

Qty _____



Batten Channel

Qty _____

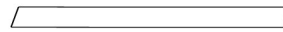

Downslope Backer Channel

Qty _____

FASTENERS



#5 1/4\" data-bbox="87 677 214 730"/>

Qty _____



#12 14x1-1/4\" data-bbox="228 677 363 730"/>

Qty _____



#14 x 7/8\" data-bbox="379 677 514 730"/>

Qty _____

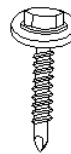

#12 x 1-1/4\" data-bbox="528 677 664 730"/>



#10 x 3/4\" data-bbox="679 677 818 730"/>

Qty _____

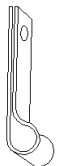

Safety Screen Clip
Spaced 12\" data-bbox="832 677 969 719"/>

SEALANTS

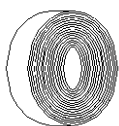

2-1/2\" data-bbox="87 878 216 913"/>

Qty _____

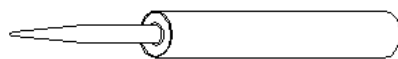

Polyurethane Sealant 10 OZ
Cartridge

Qty _____

SPACER—EXANSION JOINT



1/4\" data-bbox="610 878 804 914"/>

Qty _____



IMPORTANT: The RS24 Skylight System is designed to be installed after the roof has been put in place. The skylight system includes components required to allow the units to expand and contract with the roof sheeting.

- 1 The curb upslope flange is located near the upslope purlin. Reference the center line of the purlin top web for center of the opening. Remove 8" of the roof panel where the skylight will be installed.

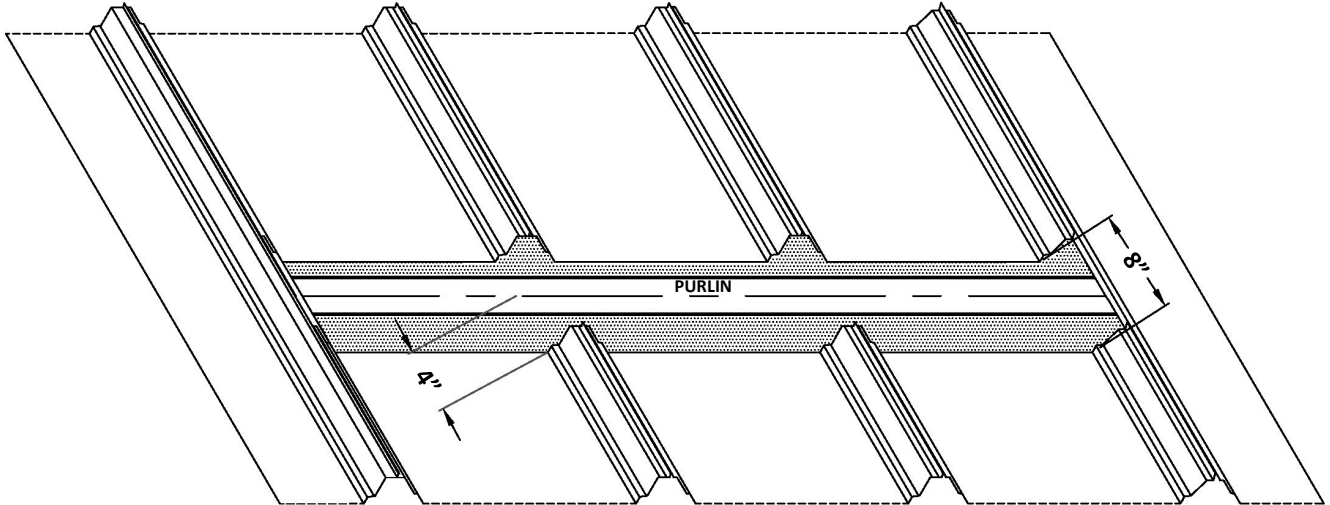

- 2 For single 10' skylights, remove 116-1/2" of roof sheeting as shown below. For multiple skylight installations up to 50', follow the schedule below. For skylights exceeding 50', leave approximately 12" of sheeting in place (to be removed at a later time) to allow for coordination of ultimate curb and skylight lengths. Do not remove roof clips when crossing purlins. Clean the sheeting area and remove metal shavings.

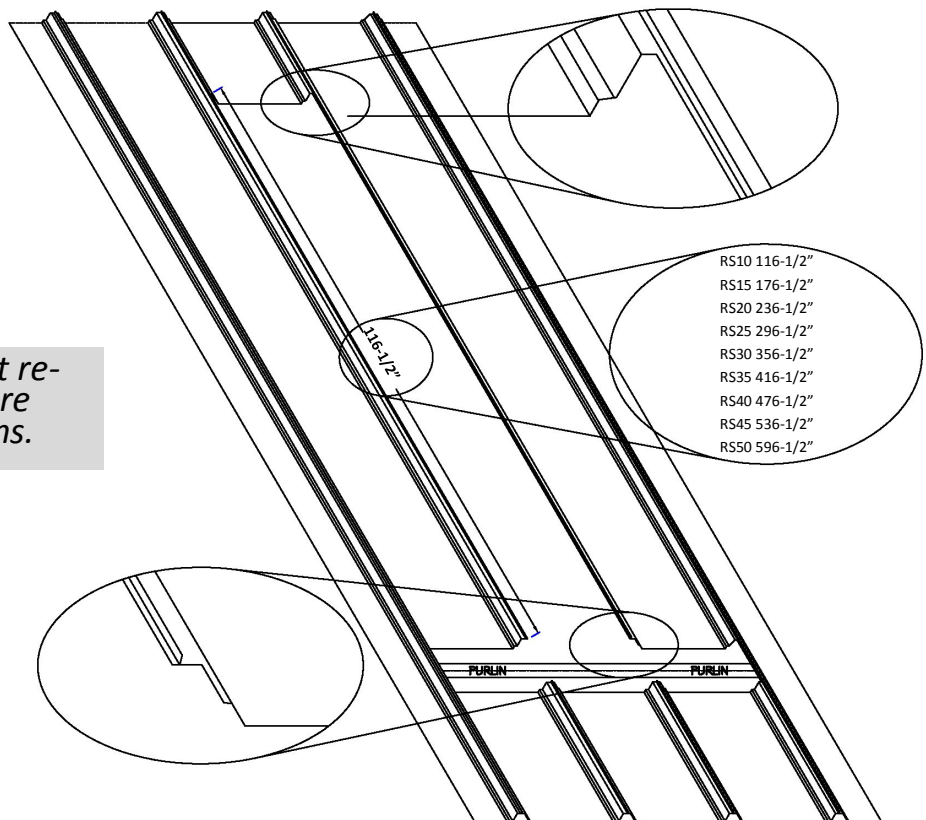

IMPORTANT: Do not remove roof clips where skylights cross purlins.

- 3** Place the steel upslope backer channel, with the 1" notch facing into the opening as shown below, under the roof sheeting and onto the purlin. Fasten the channel with six #5 shoulder tek screws to allow for roof movement.

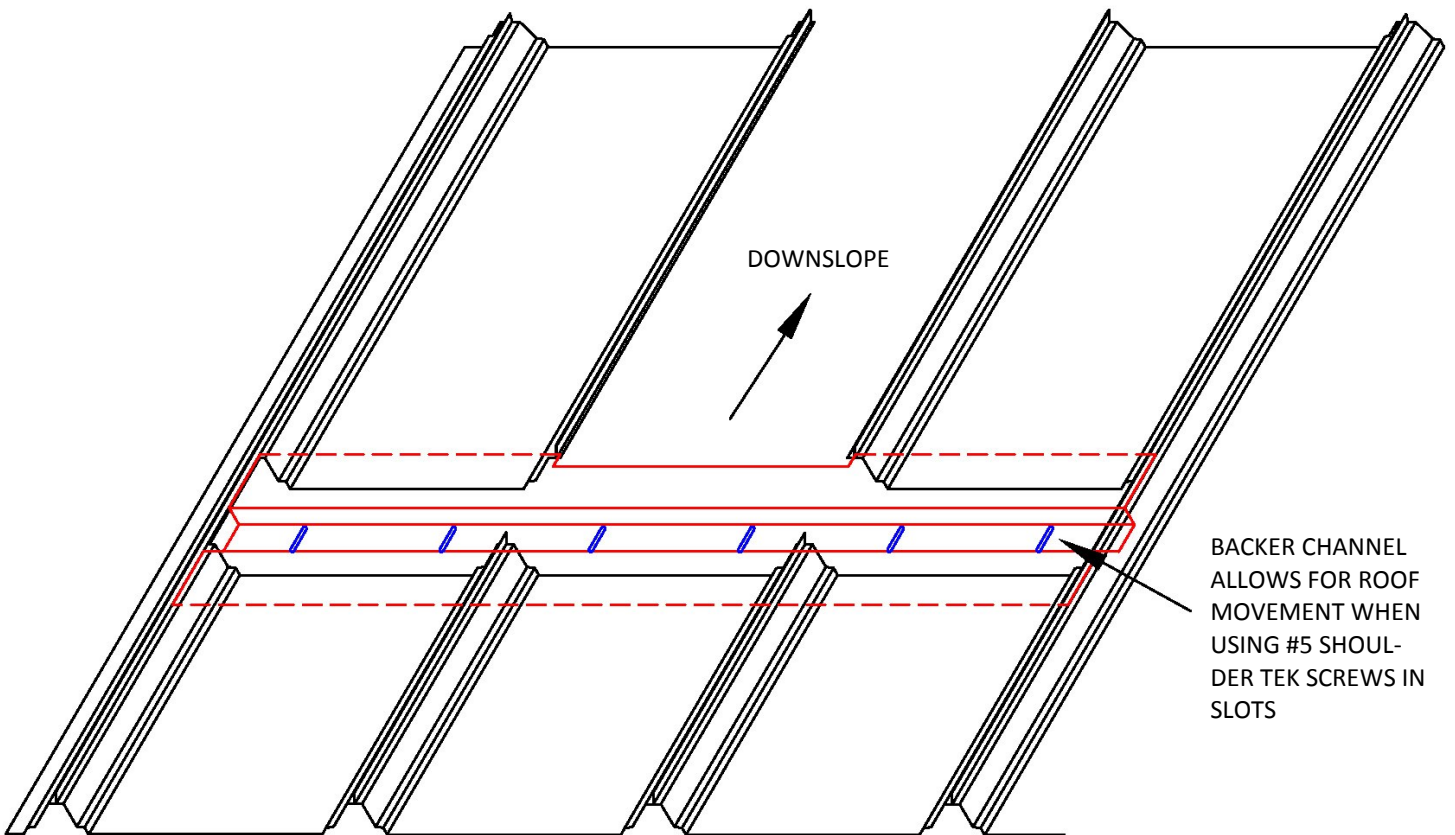
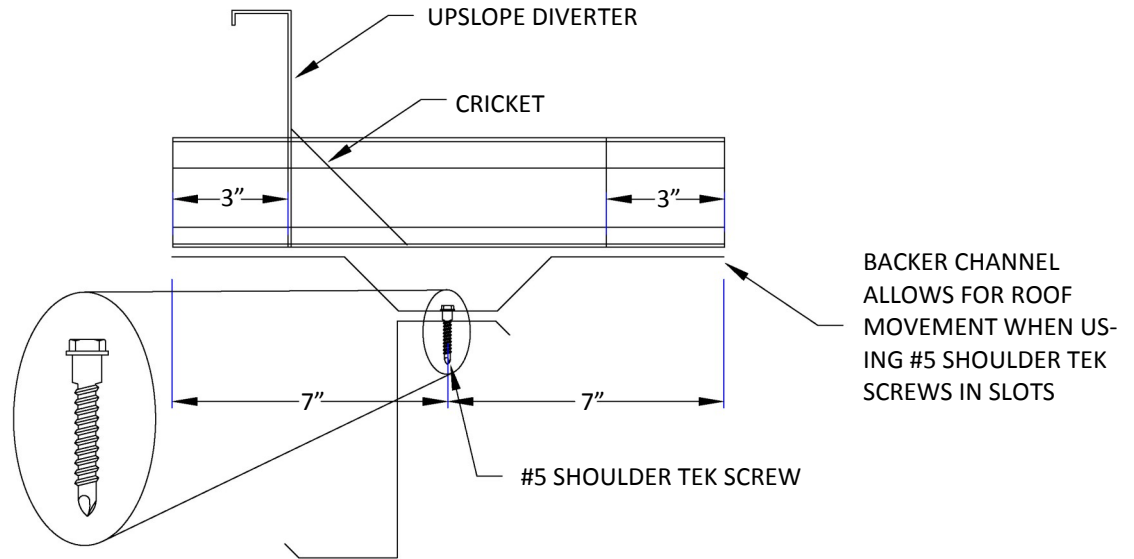

- 4** When installing a skylight greater than 10', secure the upslope curb, and side rails in place with locking pliers. Preserve a 1/4" nominal gap between all adjoining sections. Continue the process until all side rails have been secured. Mark a line matching the outline of the curb and siderails.

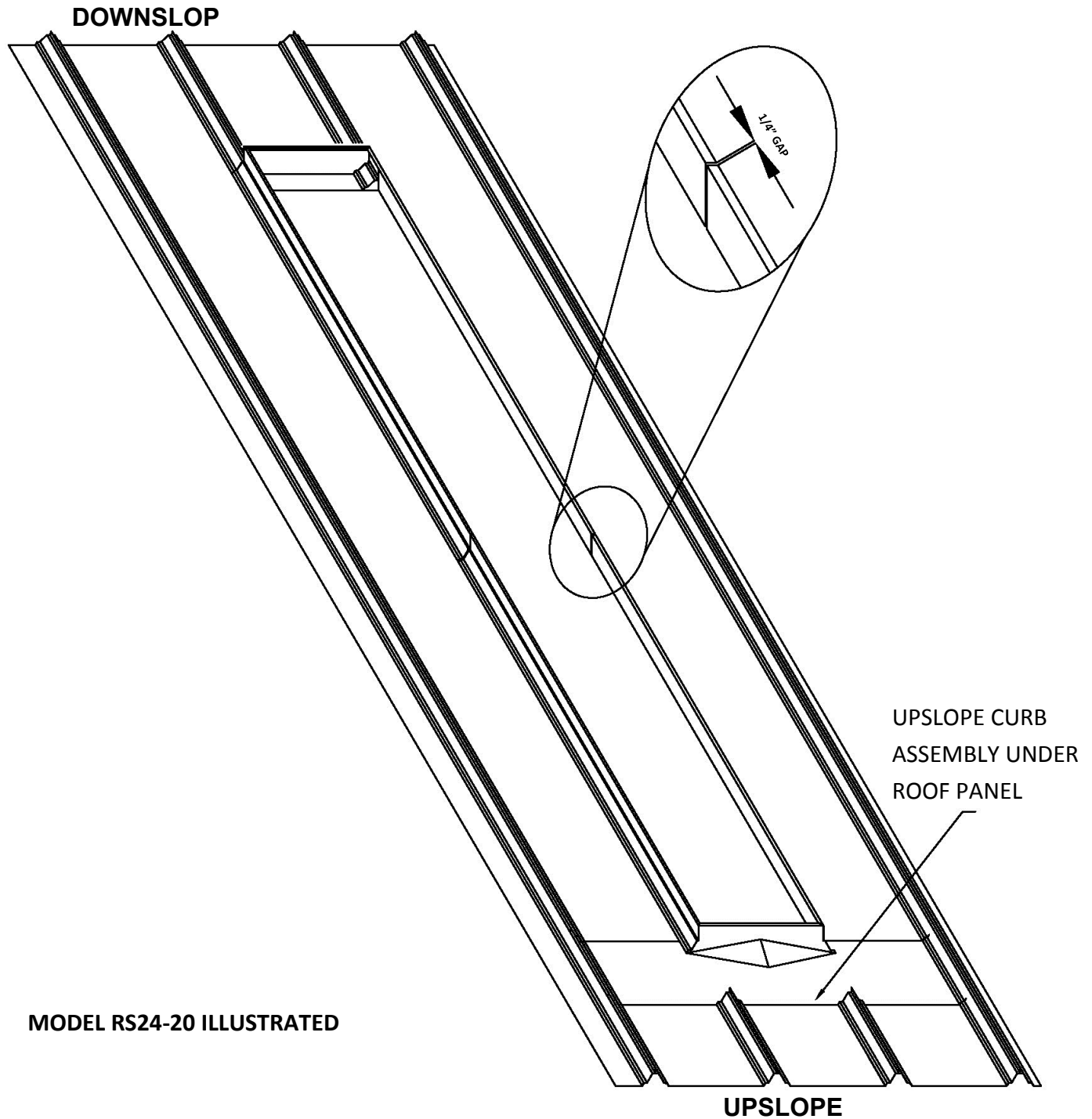

5

Remove the curb and clean the sealing surfaces. Place 2-1/2" of butyl sealant over the panel within the outline drawn in step 4. Place another 2-1/2" of butyl sealant over the leading edge of the curb. Run a 3/8" bead of polyurethane over all mastic surfaces. Prepare the seam clips and expansion joint face with mastic and polyurethane sealants and as shown below.

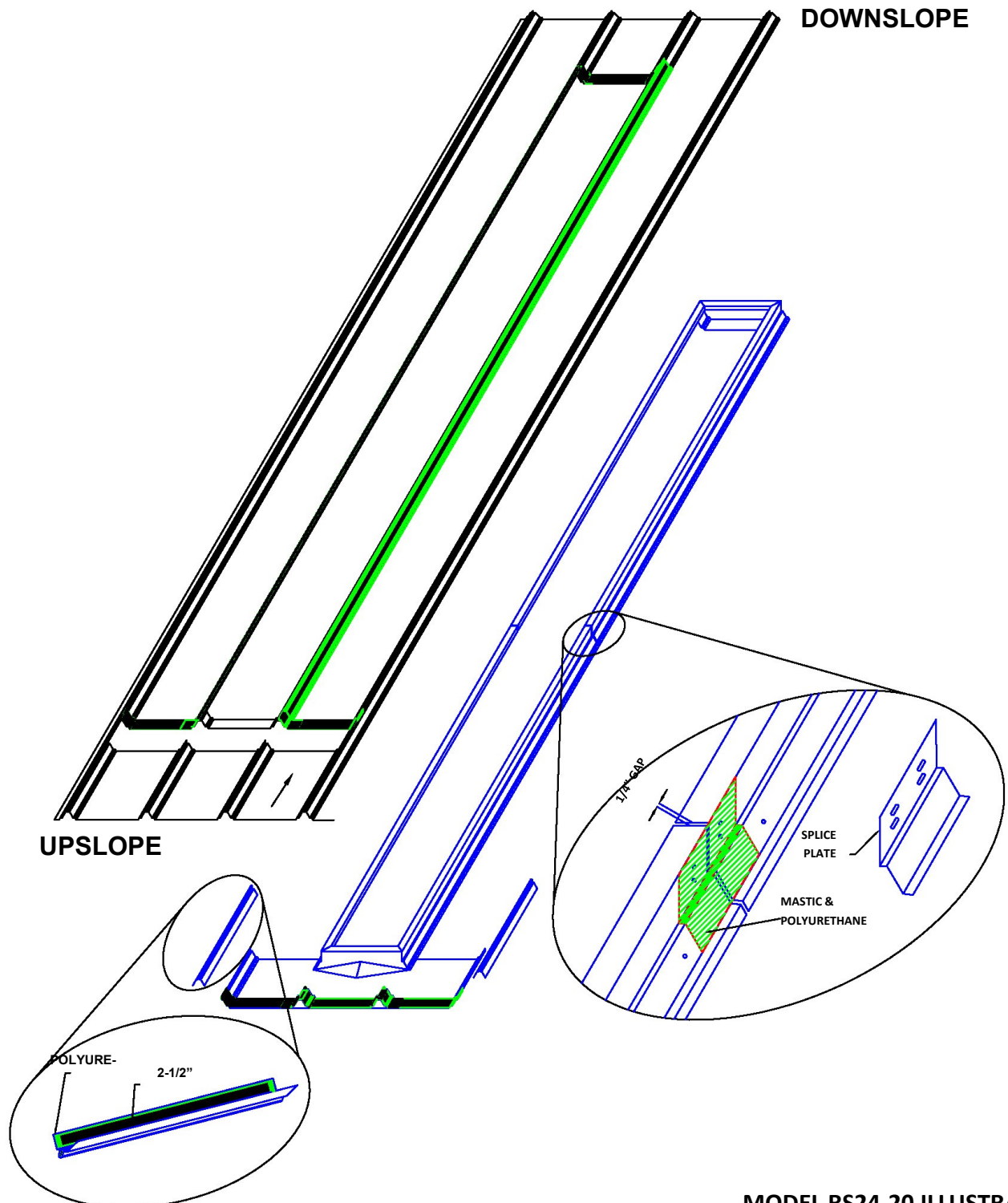

MODEL RS24-20 ILLUSTRATED

Questions or Need Assistance? 800-423-1619

- 6** Install the curb with the leading edge under the roof panel and with the sides and downslope over the panel. Locate the downslope backer channel under the roof panel and downslope flange. The downslope mounting location must be within 12" of a purlin. If the curb is in multiple sections, the expansion joints should be set with a 1/4" gap. Secure all parts in place with locking pliers. Upslope and downslope flanges are secured with #12-14 1-1/4" long life integrated washered head self drilling fasteners at 4" centers so that the sealing washer is flat on the outside surface. Secure sufficiently so a small amount of sealant is exposed along the sides. Attach the seam clips and side rails with #14 7/8" long life integrated washered head self drilling fasteners, 6" on center on both sides of the seam clips. Caulk (with mastic and polyurethane) and secure splice plates if provided. Splice plates are secured using #14 7/8" self-drilling shoulder screws and flanged shoulder spacers

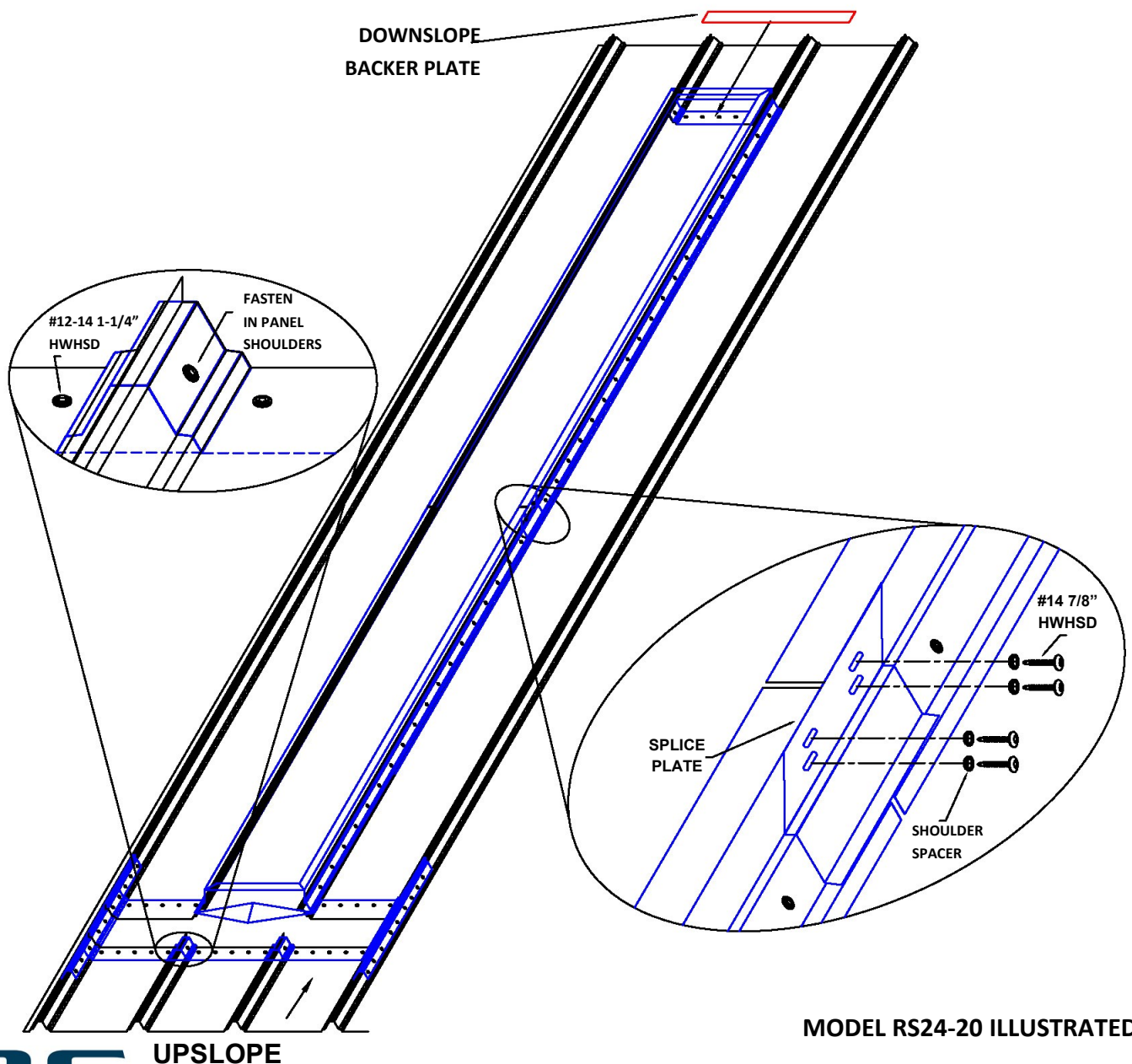

MODEL RS24-20 ILLUSTRATED

- 7** Remove the fiberglass insulation on the inside area, leaving a 2-3" perimeter. The facing remains in place. Cut the insulation facing as shown below.

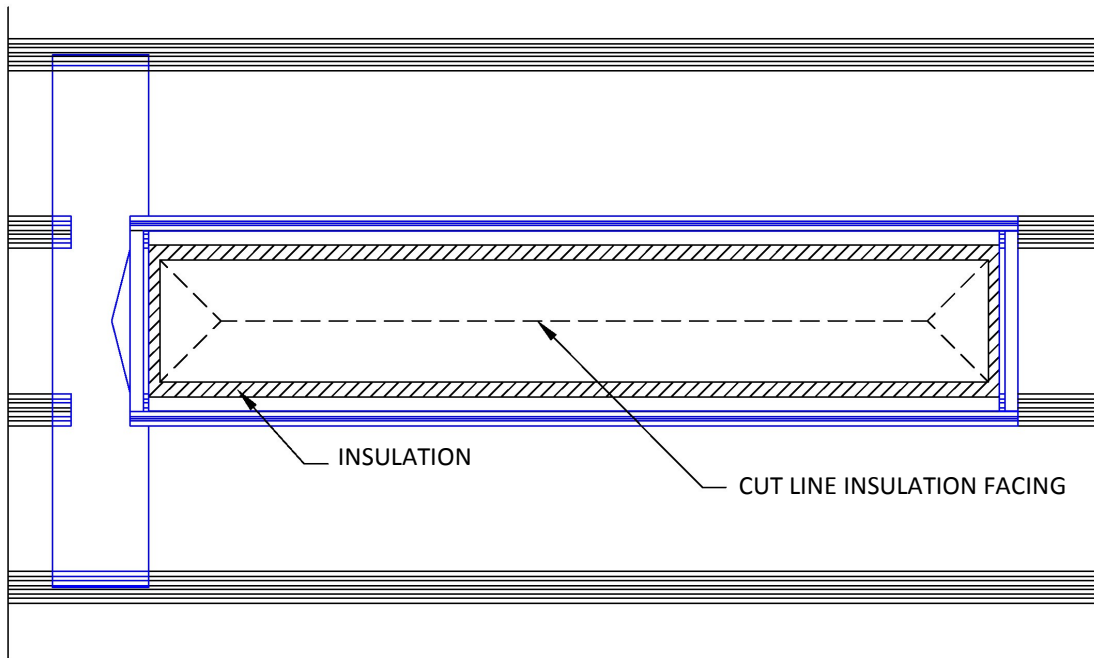

- 8** Terminate the exposed facing in any of the following ways. Tape the exposed facing if necessary.

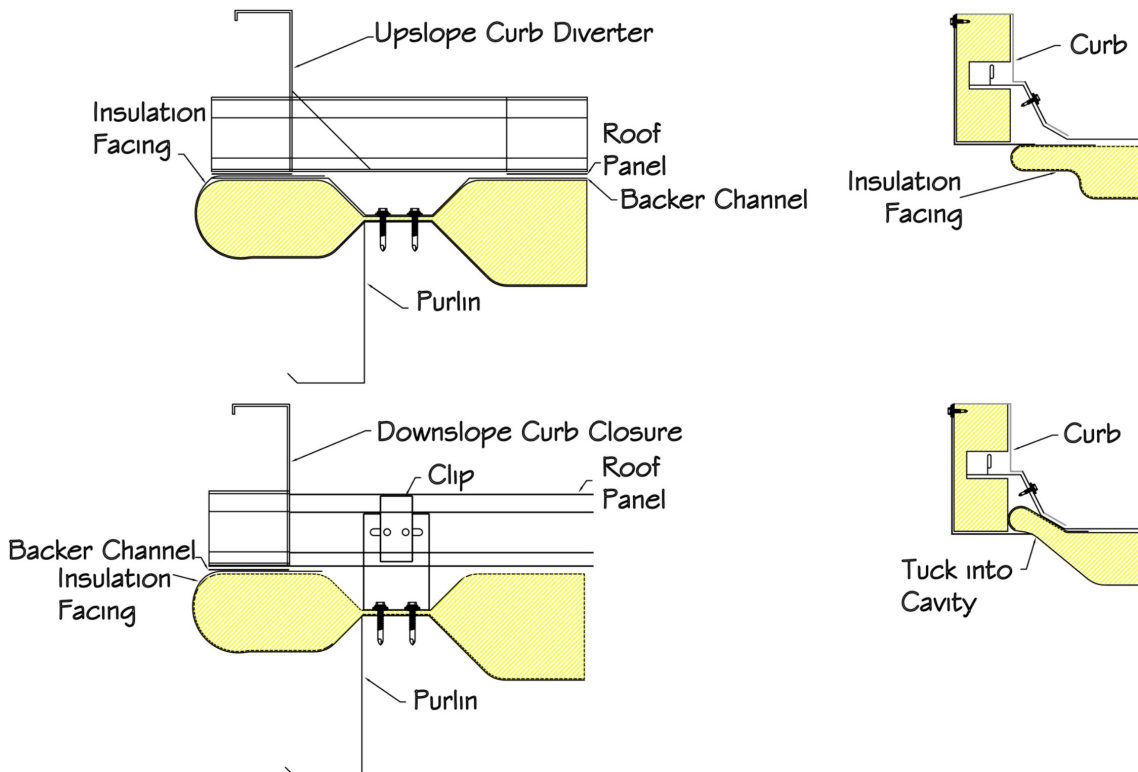

- 9** Install the side wall insulation and liner panels as shown. The insulation is notched to surround the remaining roof panel. The liner panel is placed over the insulation and fastened with self-drilling screws in the pre-punched holes. If safety screen is included, position as shown in step 10, and use the self drilling fasteners to secure the liner and safety screen assembly at the same time using the same pre-punched holes.

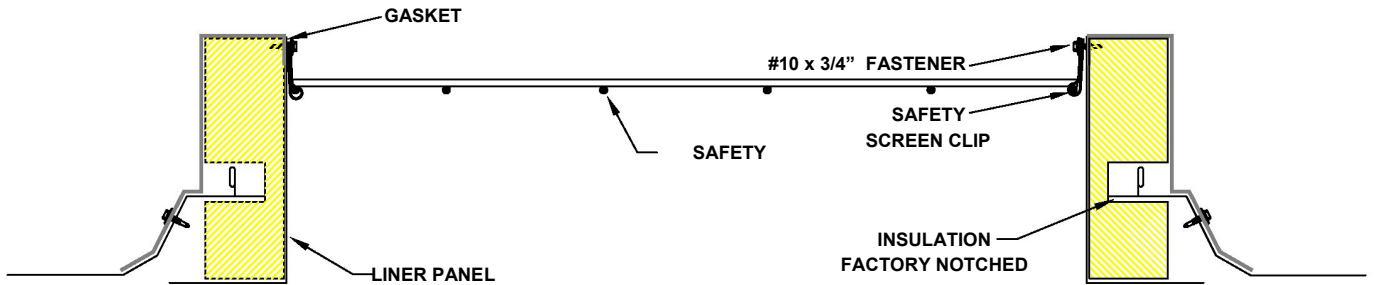

- 10** If the **safety screen** option is included, align the screen over the opening as shown. Using the clips, gasket, and fasteners provided, fasten a clip every 12" around the perimeter. See detailed clip positioning above.

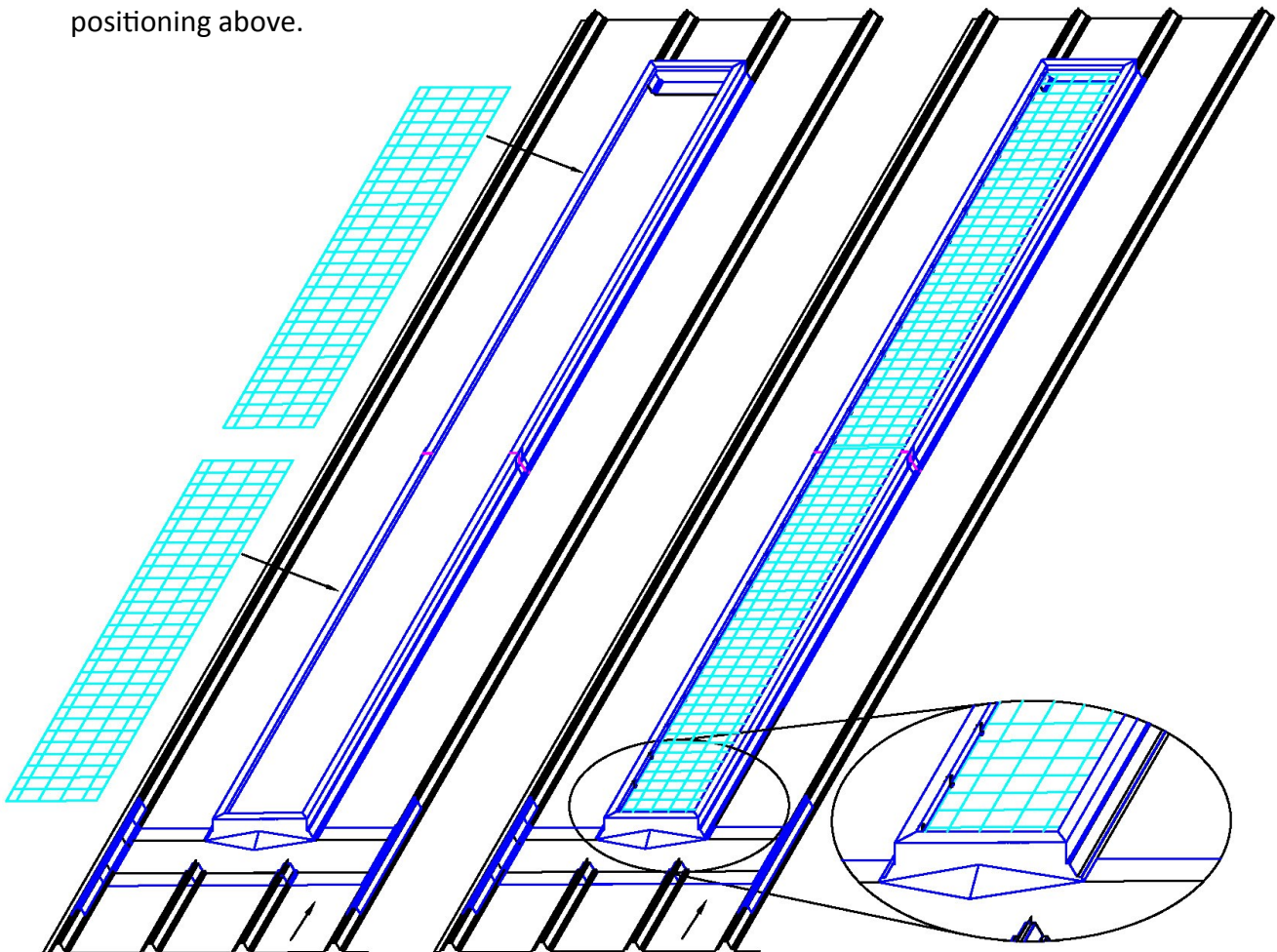

UPSLOPE

MODEL RS24-20 ILLUSTRATED

Questions or Need Assistance? 800-423-1619

11

With the first two lengths of curbing installed, the first upslope skylight may be set. Starting at the upslope diverter, install the first RS24 skylight so it is centered on the curb and so it compresses the foam rubber gasket to the curb. If there is a 5' section, it is placed at the downslope position.

The first skylight in the sequence is constructed with one short side having a reverse batten frame facing up. Position the skylight with the reverse batten facing downslope. Secure the upslope and sides of the skylight frame to the curb in pre-drilled holes with #12 1-1/4" self-drilling fasteners, shimming to avoid excessive stress on the skylight frame. *Do not over tighten the fasteners.*

The first batten assembly centerline should be aligned with the curb splice centerline. If it is off center, add or subtract to the expansion joint gap (minimum gap is 1/8") on the next curb rail assembly as necessary. Once the first skylight is secure, another section of curb should be installed as described earlier in steps 4 thru 10.

The next skylight module will be fitted with an upslope batten frame, and possibly a downslope frame (unless it is the last section). In preparation of installing the next skylight module, clean the batten surfaces, place 1-1/2" wide tape mastic over one batten, and apply a 1/4" bead of polyurethane sealant over both faces along the outboard perimeter as shown below. Butt the surfaces together assuring that some sealant emits from the joints. Use locking pliers to secure the bottom 1/2" of each batten.

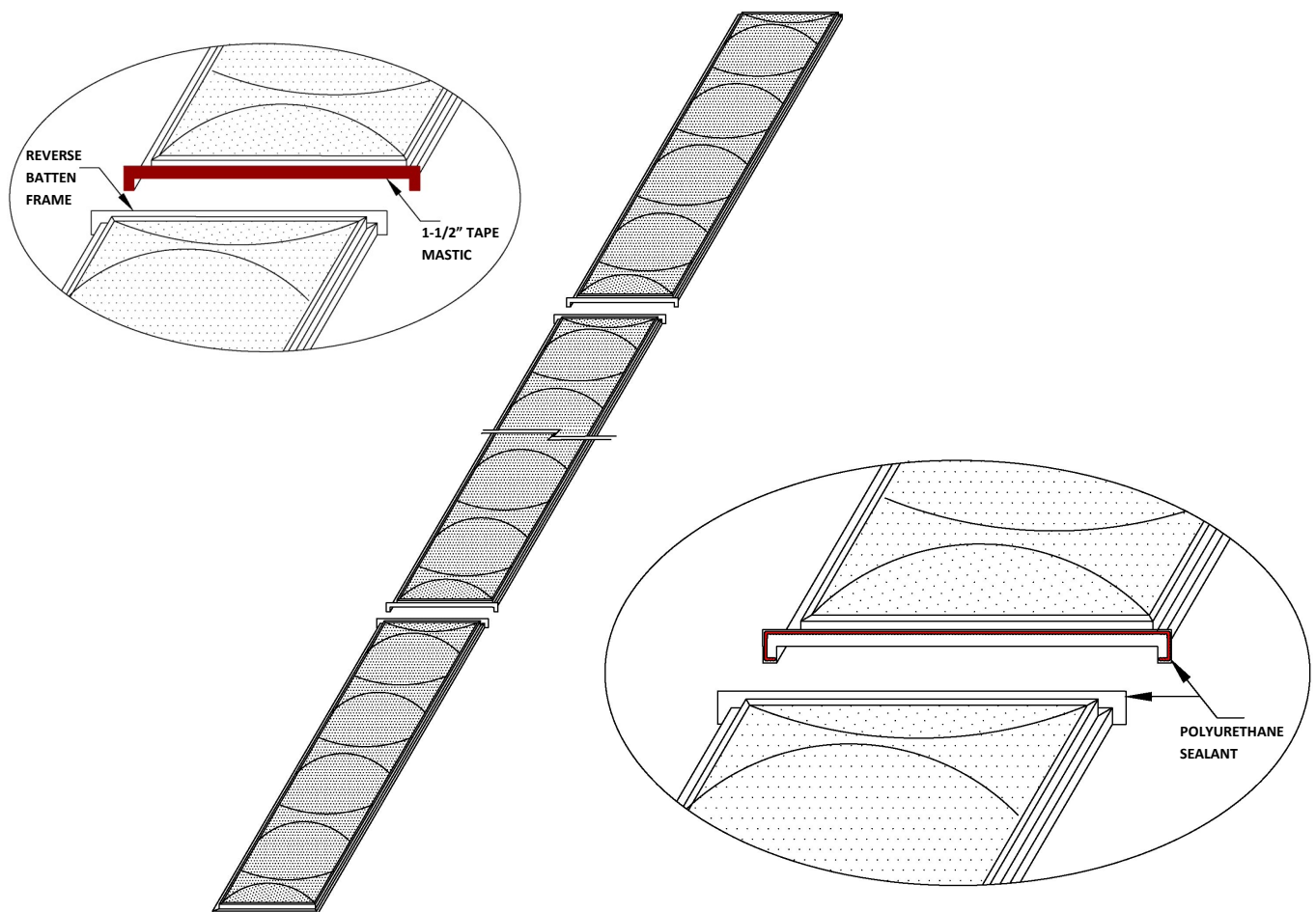

12

Fill the batten channel with a 1/2" bead of polyurethane, and place over the batten channels insuring the assembly is fully seated. With locking pliers squeezing the batten flanges together in place, secure the assembly with four # 14 x 7/8" self drilling screws as illustrated below.

Starting at the upslope diverter, install the RS24 skylight(s), centering the assembly, if multiple skylights are being installed. Secure the skylight frames to the base curbs with #12 x 1-1/4" self-drilling fasteners provided. The screws should be located in the pre-drilled skylight frame holes and shimmed as necessary so as not to stress the frame. *Do not over tighten the fasteners.*

For cold climate installations, you may place three strips of 1/4" x 1-1/2" neoprene over the exposed frame under the battens for interior condensate control. These are installed from inside the building after the skylight is fully secured.

