

FALL PROTECTION SYSTEM FOR LTP SKYLIGHTS ON R-PANEL ROOF

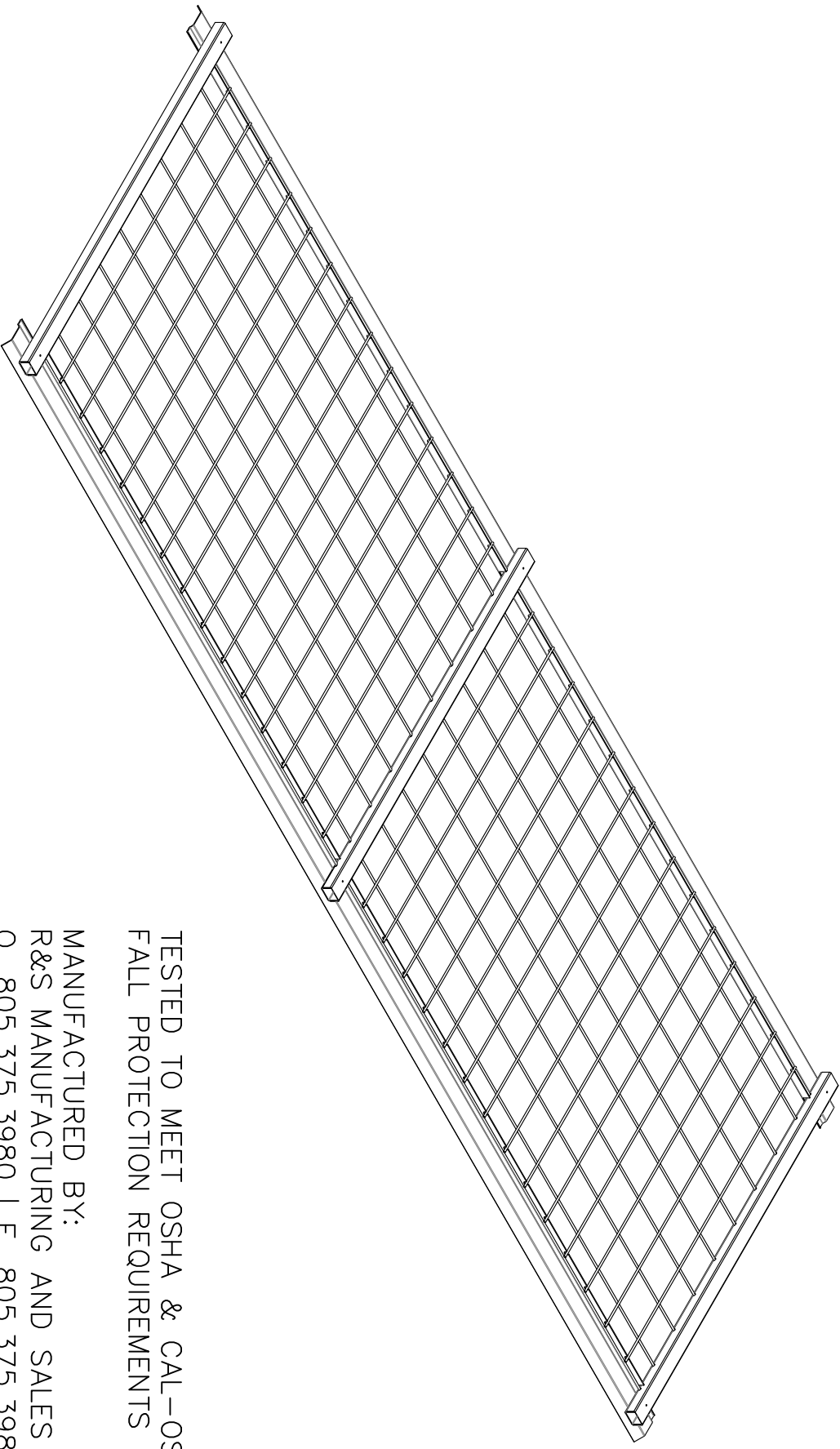

TESTED TO MEET OSHA & CAL-OSHA
FALL PROTECTION REQUIREMENTS

MANUFACTURED BY:
R&S MANUFACTURING AND SALES CO.
O. 805.375.3980 | F. 805.375.3981
SALES@RNSSALES.COM

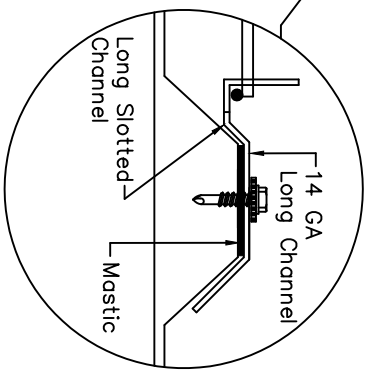
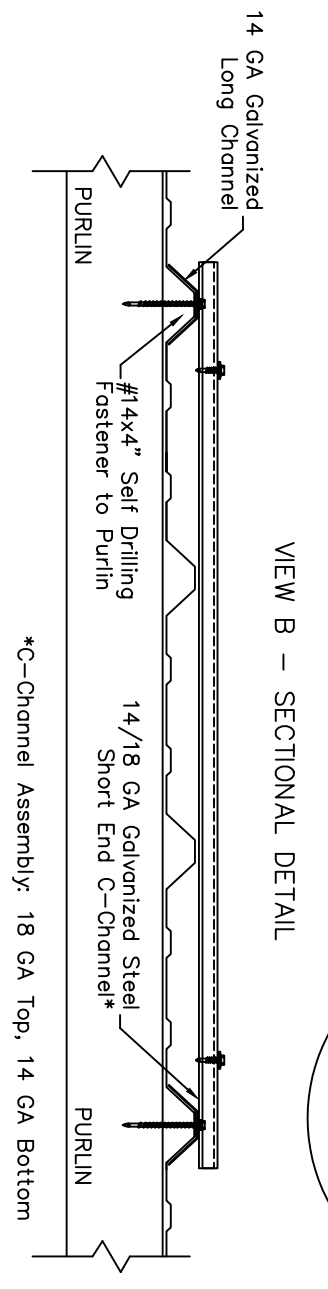
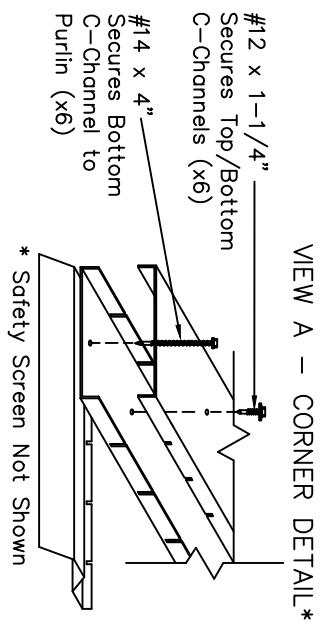
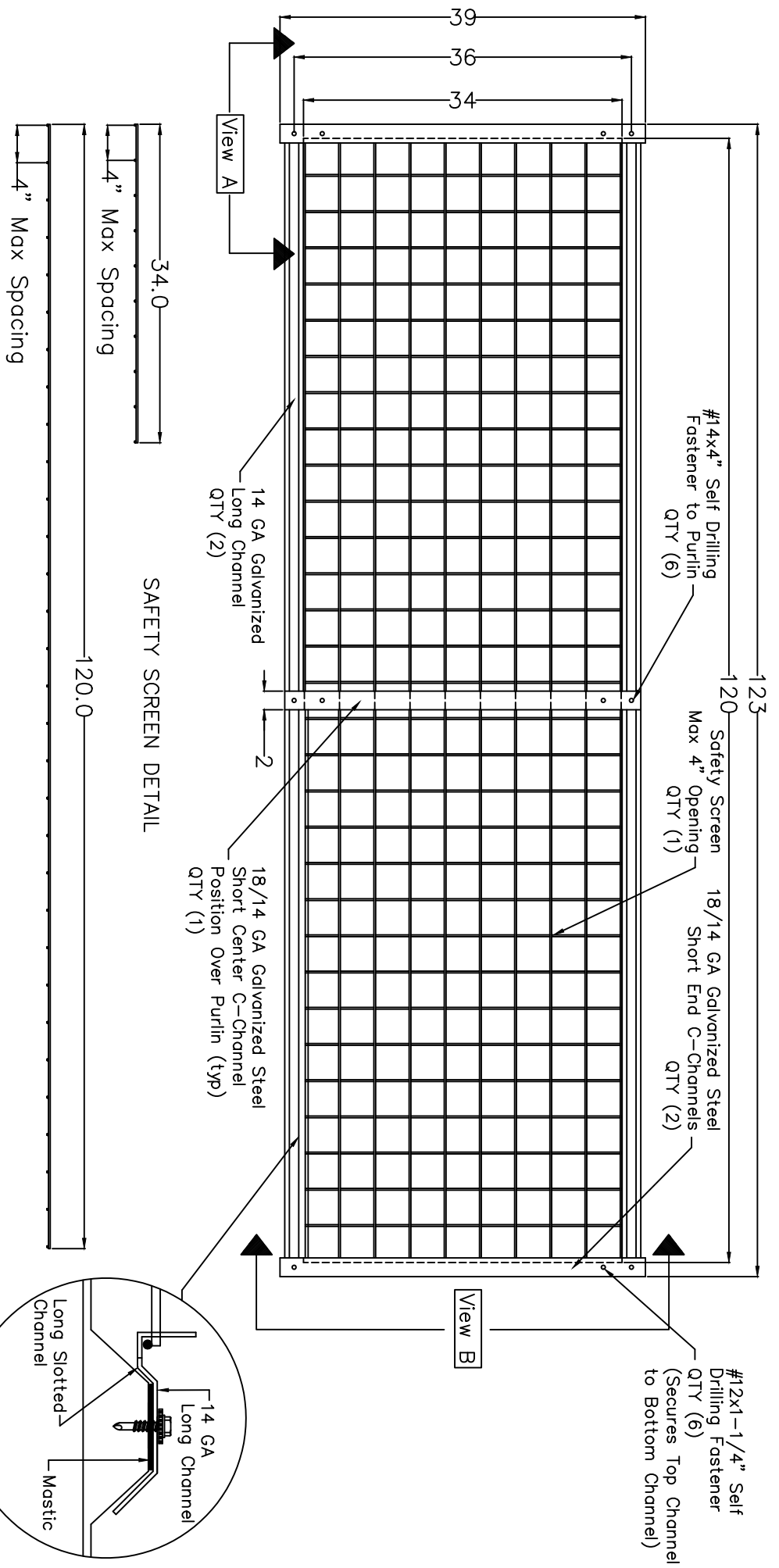

R&S Manufacturing and Sales Co., Inc.
3575 Old Conejo Road
Newbury Park, CA 91320
(805) 375-3980

Product Notes
LTP Safety Screen
OSHA Compliant to CFR 1910.23 and 1926.501
CAL OSHA Compliant to Title 8: Section 3212

Description		Customer	
LTP Safety Screen			
PANEL TYPE	R Panel (12" O.C.)	Material	3/16" Galv. Steel Screen, 14/18 GA Galv. Channel, Mounting Hardware
Scale	NTS	Drawn By	ESM
QTY		Date	10/13/16
Rev Date	10/13/16	Job	