

ASSEMBLY INSTRUCTIONS

KNOCKED DOWN RIDGE VENTS

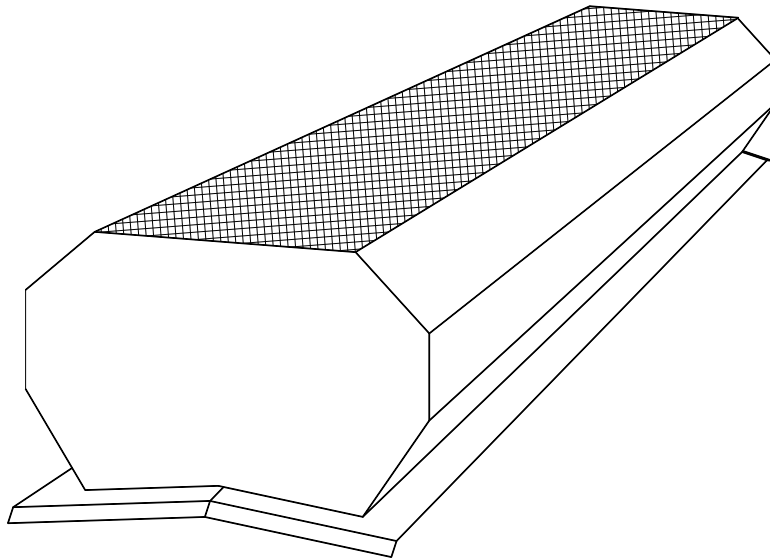

February, 2013

PARTS LIST

- End Caps (2 per vent)
- Wind Bands (2 per vent)
- Skirt Flashings (2 per vent)
- Skirt Cross Braces (3 per vent)
- Gussets (3 per vent)
- Diverter (1 per vent)
- Bird Screen (1 per vent)
- Bird Screen End Trim (2 per vent)
- End Cap Diverter Trim (2 per vent)
- End Cap Roof Flash Assembly (2 per vent)
- End Cap Continuous Flash Assembly (1 per vent)

Fasteners:

- 1/8 X 1/8 ALL ALUMINUM POP RIVET PART #AB42A (For use with RV Windbands)
- 1/8 X 1/2 ALL ALUMINUM POP RIVET PART #AB48A (For RV Screen)
- 1/8 X 1/8 ALUMINUM/ STEEL POP RIVET WITH CLOSED END PART #AB42CLD (For RV-9 Diverter)
- 3/16 X 1/4 ALL ALUMINUM POP RIVET WITH CLOSED END PART #AD64AH (RV-12 Diverter)

Sealants:

- Schnee-Moorehead S-M 7100 polyurethane sealant

For Vents with Dampers:

- Damper (1 per vent)
- Damper Horizontal Guide (1 per vent)
- Damper Chain Attachment Bracket (1 per vent)
- Damper Guide Rod (1 per vent)
- Damper Guide Rod Bushing (1 per vent)
- Damper Guide Base (1 per vent)
- Damper Lift Arm (2 per vent)
- Damper Pull Angle (1 per vent)
- Operator Chain (15') (1 per vent)
- Extension spring 7/16" OD 16-3/8" overall length (1 per vent)

Fasteners:

- 1/4" x 1-3/4" zinc finish carbon steel clevis pin (four per vent)
- 1/4" x 1-1/2" zinc finish carbon steel clevis pin (two per vent)
- 3/16 X 1/4 ALL ALUMINUM POP RIVET WITH CLOSED END PART#AD64AH (RV Diverter Guide Rod Bracket)
- 3/16 X 1/4 ALL ALUMINUM POP RIVETPART#AB64A (RV damper clip)
- #4 Aluminum Eye & Eye 1/4-20 turnbuckle. 5-1/2" long closed. 7-5/8" long open with nut & bolt for attachment (1 per vent)
- Palnut Model PS250085 Flat Round Pushnut fasteners (1 per vent)
- Heyco Bushings Part # SB 437-5 black (1 per vent)

Lay the three gussets on a table with all 3 pieces facing the same direction spaced about 3 feet apart. Lay the diverter on top of the gussets. Tip the gussets up one at a time with the "horseshoe" facing up and fasten the diverter to the gussets with 1/8 X 1/8 ALUMINUM/ STEEL POP RIVET WITH CLOSED END PART#AB42CLD (RV-9 only). For the RV-12 and up, use 3/16 X 1/4 ALL ALUMINUM POP RIVET WITH CLOSED END PART#AD64AH.

Six rivets required.

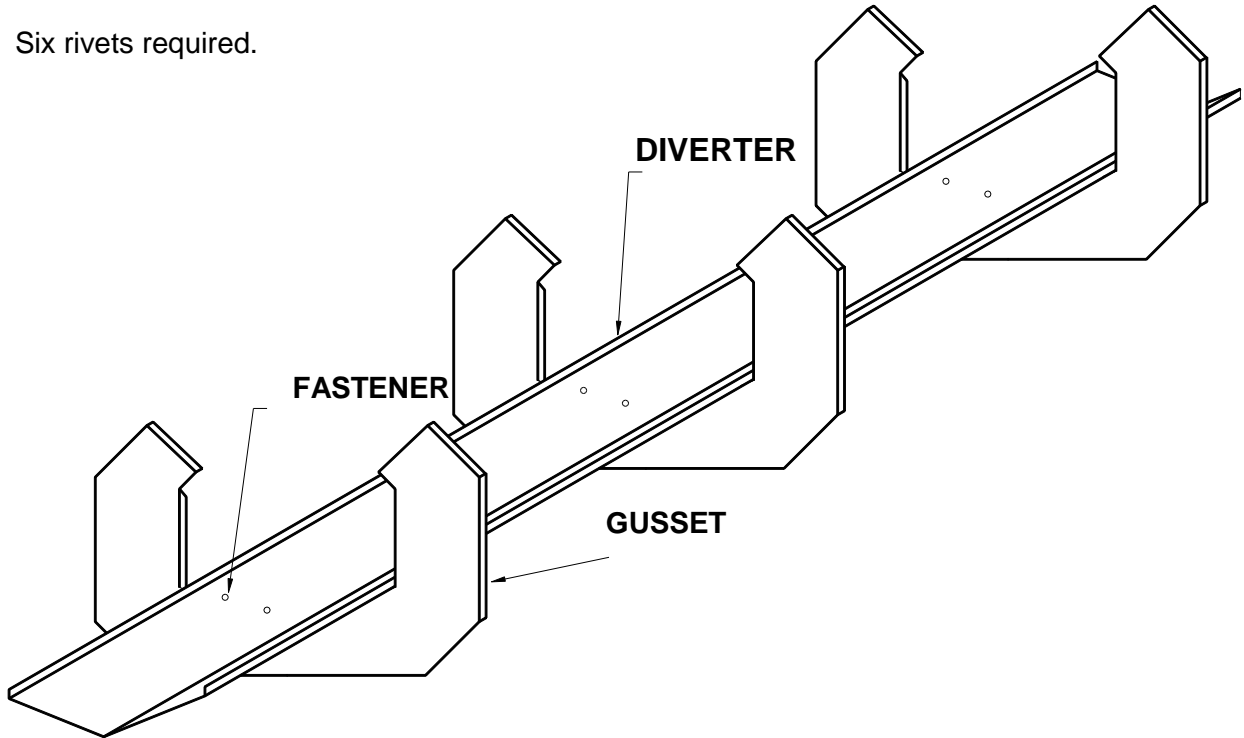

If the vent includes a damper, set up the damper guide rod into the damper guides with push-nut fasteners at the end of the rod. Attach the damper guide assembly to the diverter using two 3/16 X 1/4 rivets with closed ends.

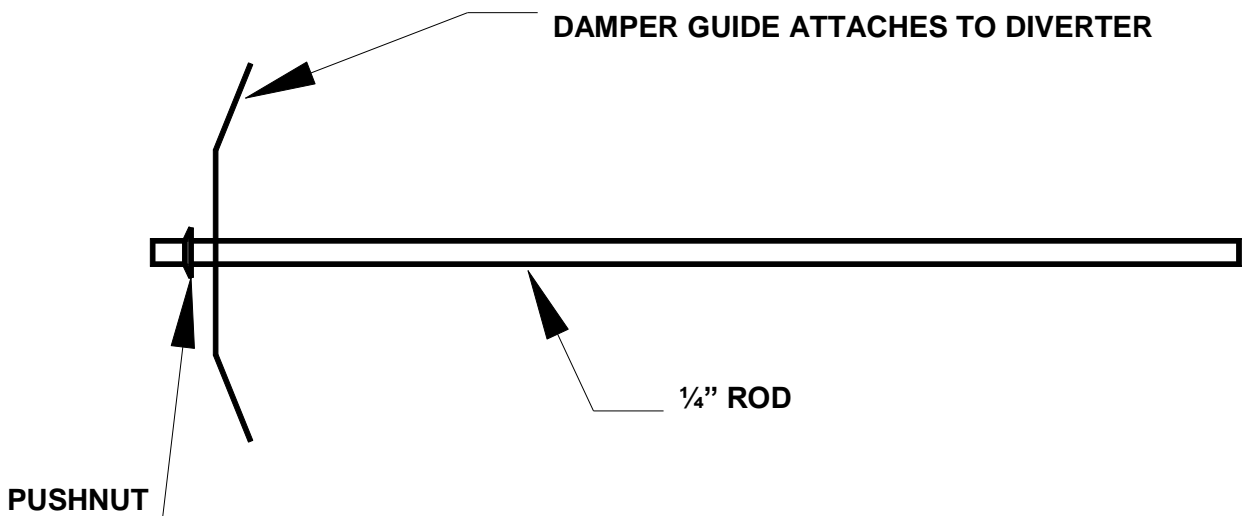

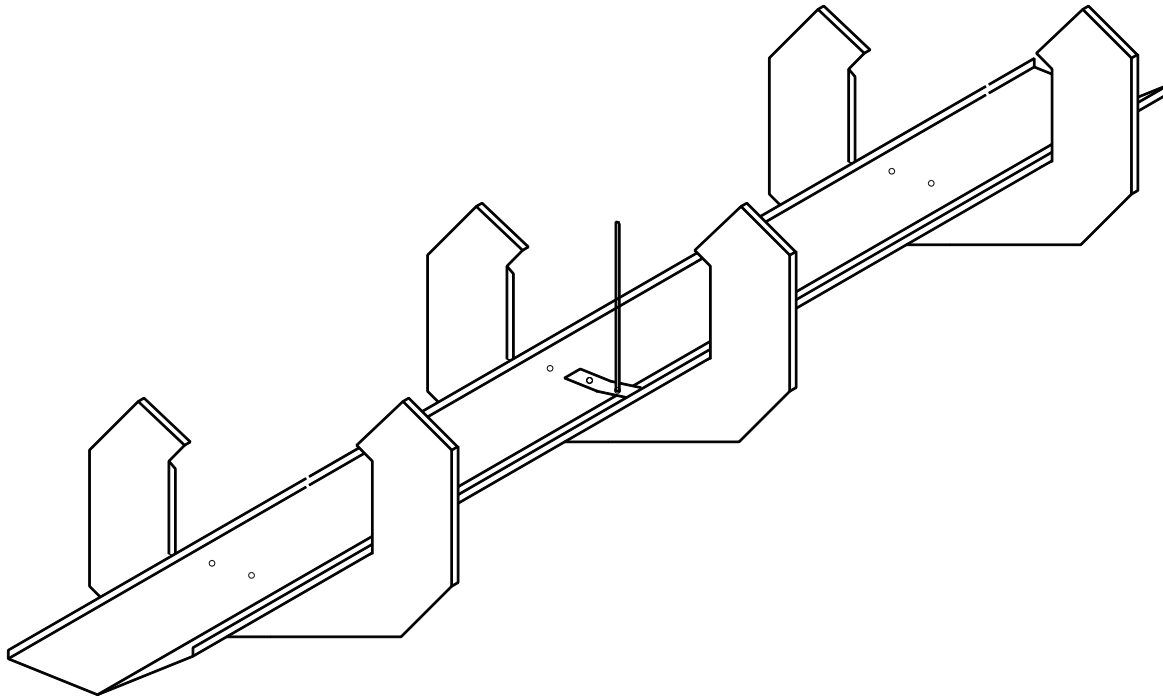

Set up the damper with one Heyco guide rod bushing, and the one damper horizontal guide assembly. Use two 3/16 X 1/4 rivets PART#AB64A.

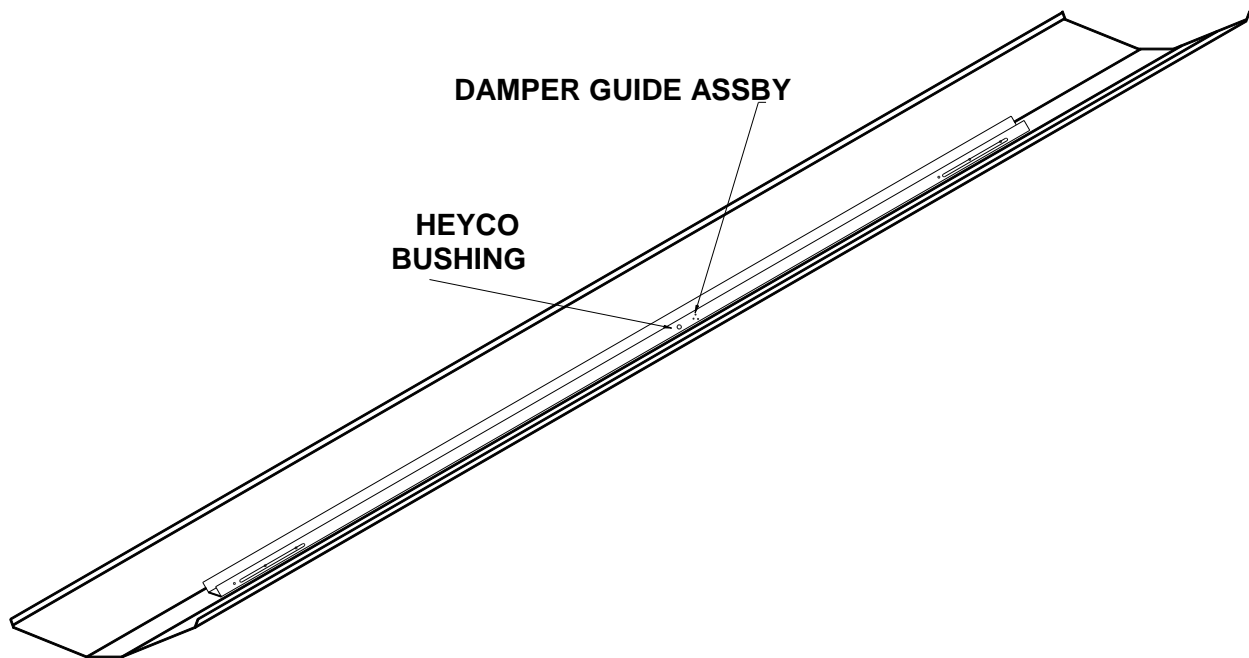

Place damper assembly over guide rods and diverter.

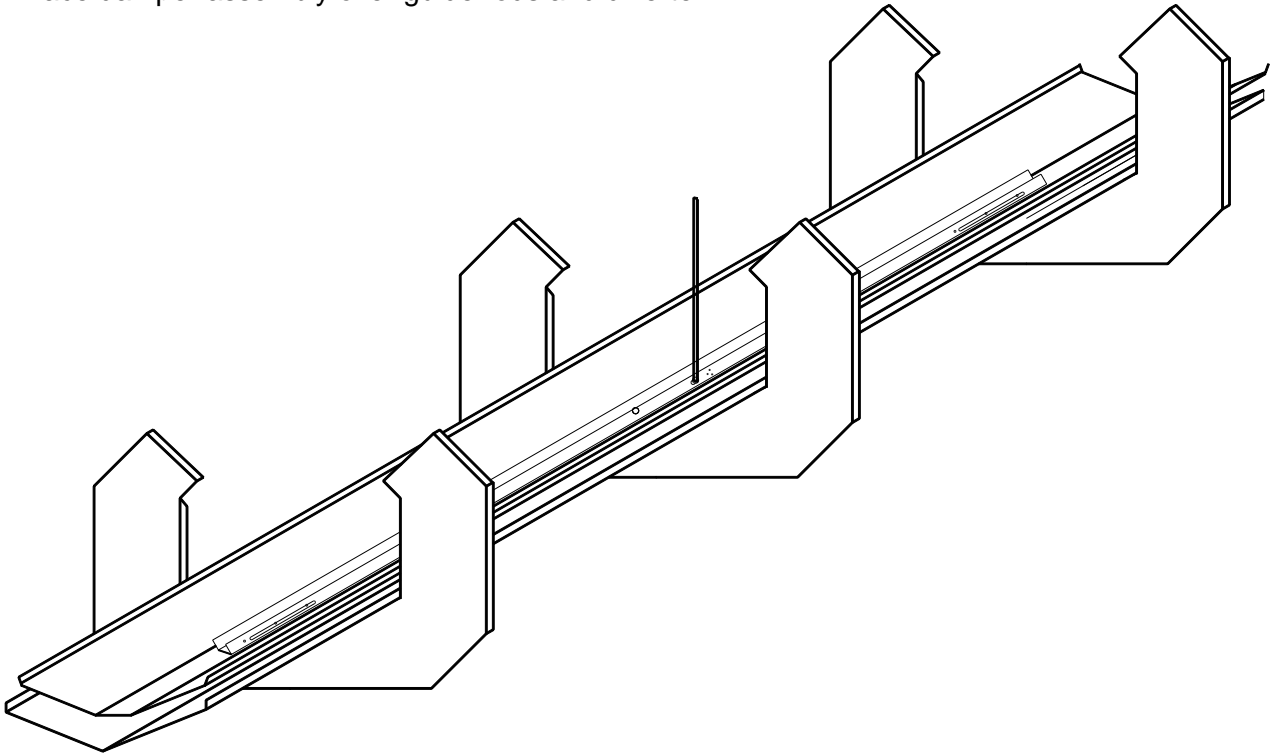

Lay the two skirt flashings on top of the gussets making sure the holes line up properly.

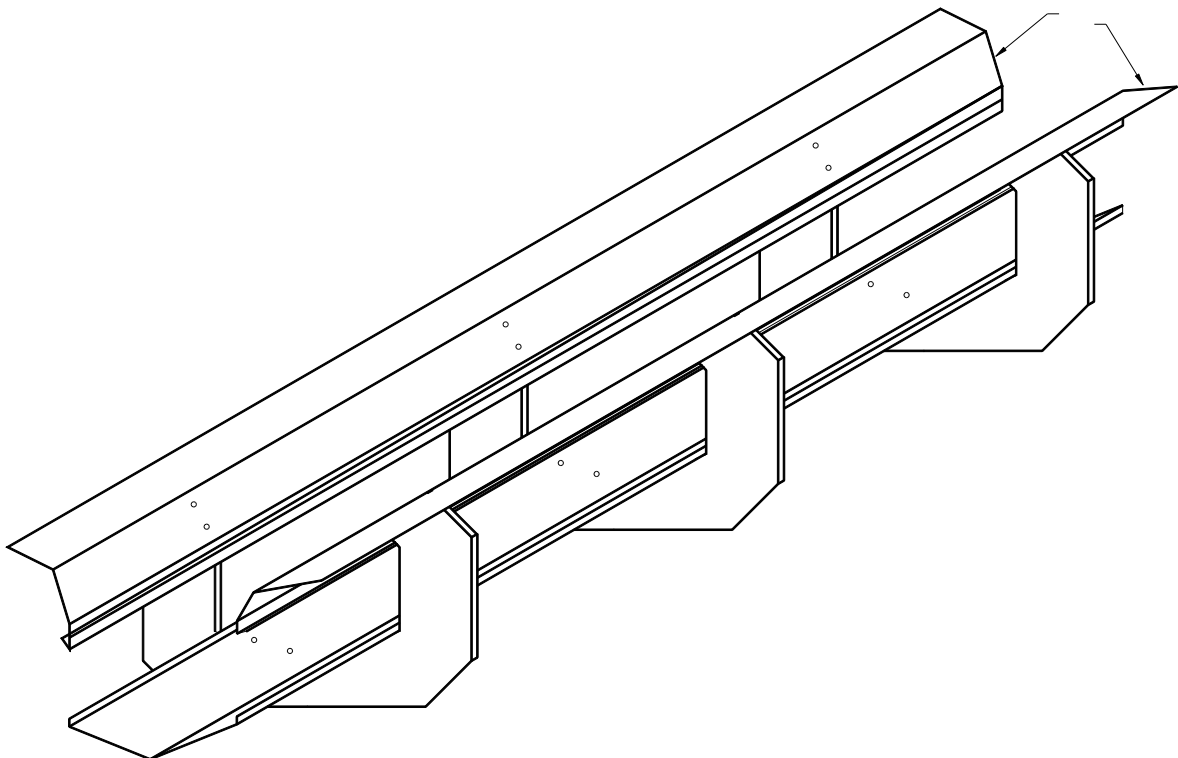

Apply a small amount of sealant over each skirt rivet hole where the braces attach (on the side facing the brace). Next, position the braces over the top of the skirts in the orientation shown. The middle brace is unique with a pathway and keeper provided for the chain operator and guide rod. Using 3/16 closed end rivets, fasten the skirts and braces to the gussets.

12 Rivets required.

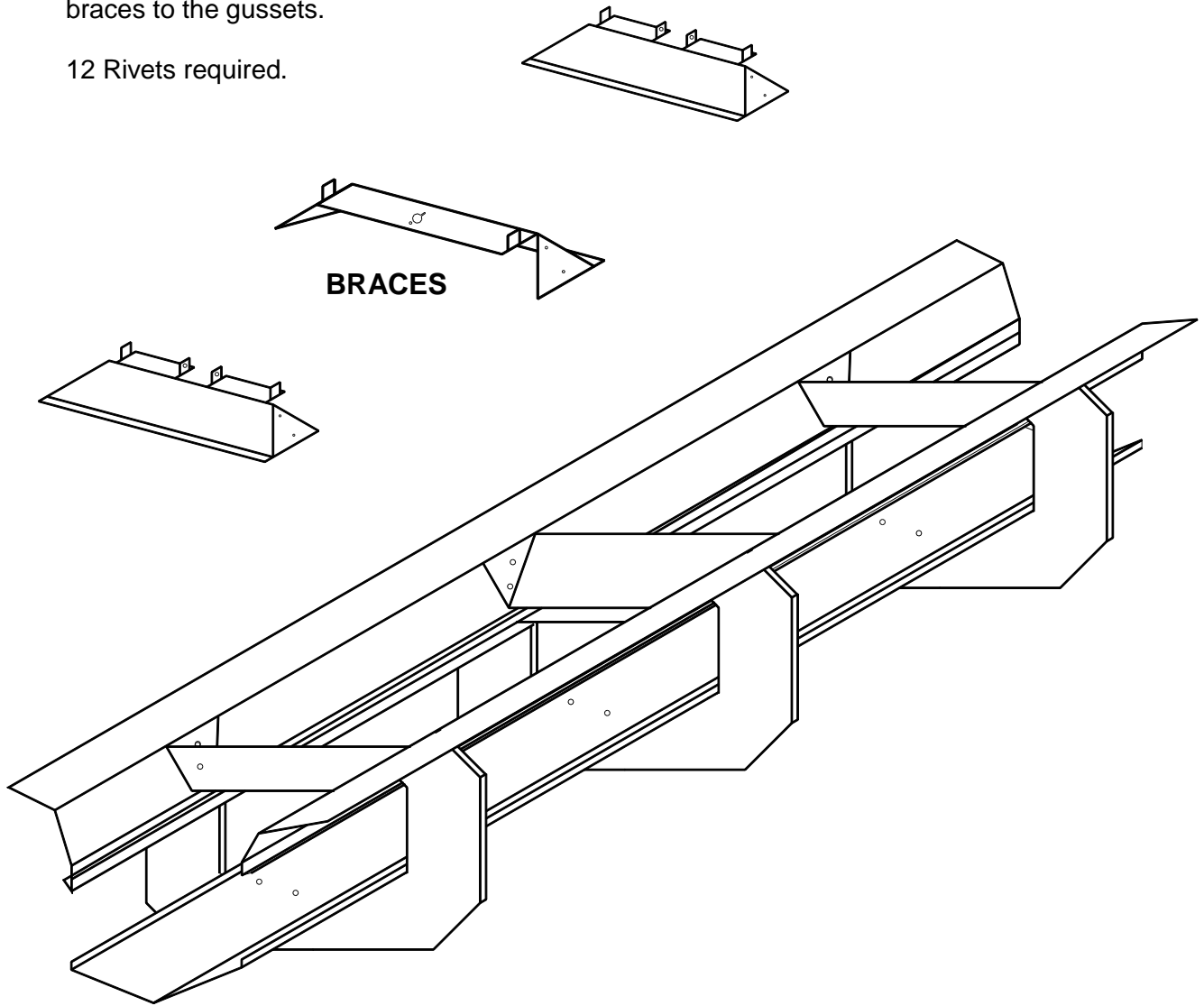

Place the two damper operator arms (long side connects to the damper assembly) into the end braces. Use clevis pins to fasten to damper. Then place the damper pull angle as shown and connect to the damper operator arms with clevis pins. Connect the counter balance extension spring between the end brace and pull angle as shown using the S hook and a self tapping screw.

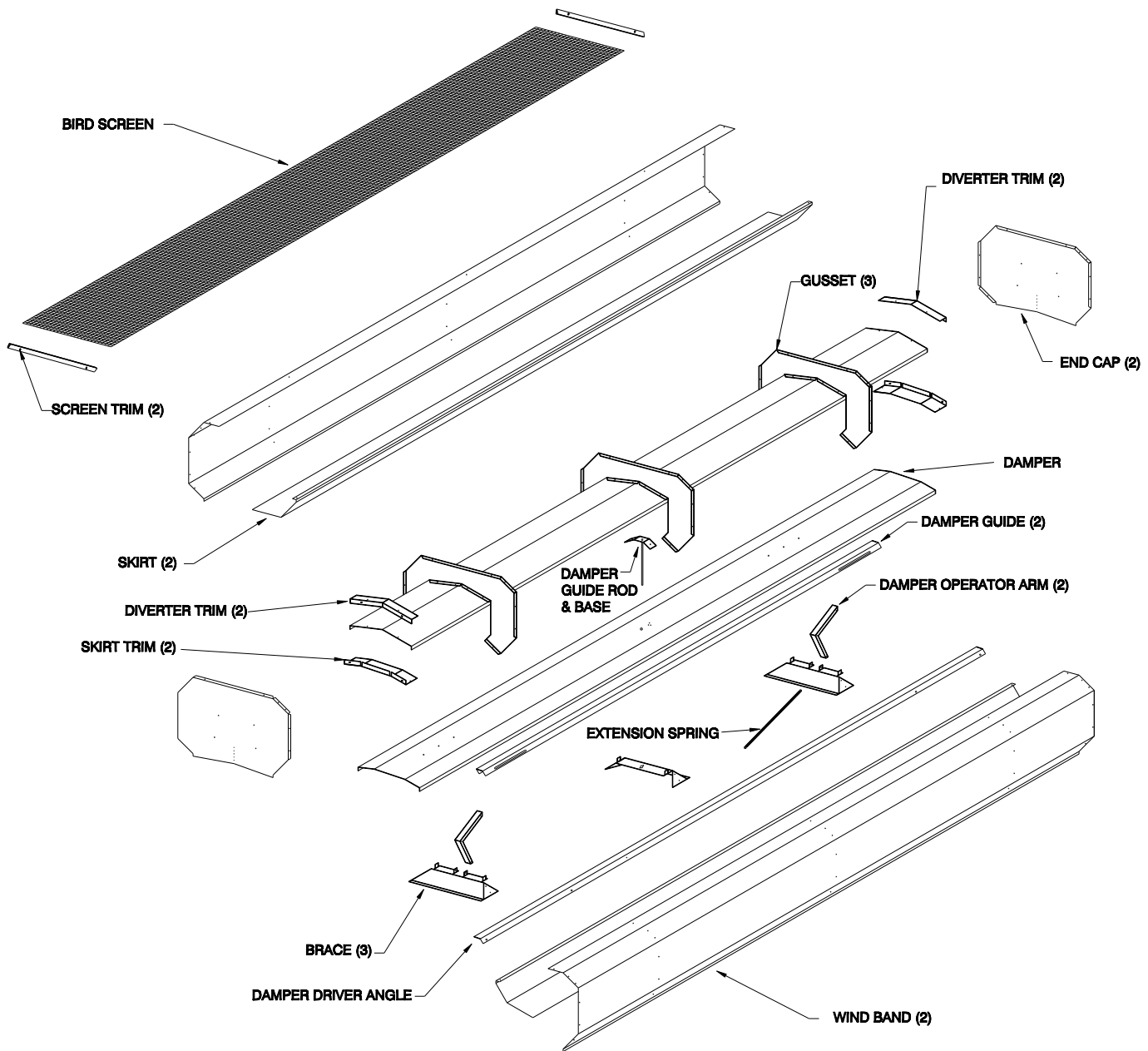

Fasten the windbands (RVWBAND) to the sides of the gussets using 1/8" rivets. Do not fasten the windband to the braces near the bottom to allow the screen to be inserted.

1. Form the (RVDIVTRIM) by hand to match the shape of the water diverter and fasten one to each end of the diverter using 1/8" rivets.
2. Form the (RVSKIRTTRIM) by hand so the 1/8" holes in the end (not the slots) match up with the holes in the ends of the skirts. Fasten to the skirts using 1/8" rivets.
3. Attach the ends (RVENDCAP) to the end of the vents with the windbands overlapping the flanges on the end caps. Fasten using 1/8" rivets.
4. Caulk the (RVENDCAP) to the (RVDIVTRIM) and the (RVSKIRTTRIM) using the polyurethane caulking.
5. Attach the (RVENDCAP) to the windbands (RVWBAND) using 1/8" rivets.
6. Turn the vent over 180 degrees and slide in the screen.
7. Trim the screen to be approximately 1/8" shorter than the vent after it is in place.
8. Attach the (screen-trim) using 1/8" steel shank rivets.

