

UL LISTED - DOUBLE DOME

SPECIFICATIONS

- Fully Welded & Assembled Curb 18 GA G90 Steel or 0.063" Aluminum
- Base options include self flashing, curb mount and metal building
- White 0.118" Copolyester outer domes
- Clear 0.030" inner domes
- 40% Visible Light Transmittance with 100% Haze Factor
- 0.50 Solar Heat Gain Coefficient
- 0.53 U Factor
- Dome Frames with sealants and Condensate provisions
- 1" Rigid Insulation R7.2
- Full perimeter EPDM bulb gaskets
- Lids open against a 10 PSF live load
- Lid uplift rating 30 PSF
- Hinges and latches 12 GA galvanized steel
- Latches rated for 90 PSF uplift
- UL listed fusible or McCabe resettable links
- Inside and outside manual releases
- High performance gas springs with hold open
- 4" x 4" x 3/16" Galvanized Steel OSHA Compliant Safety Screen Option

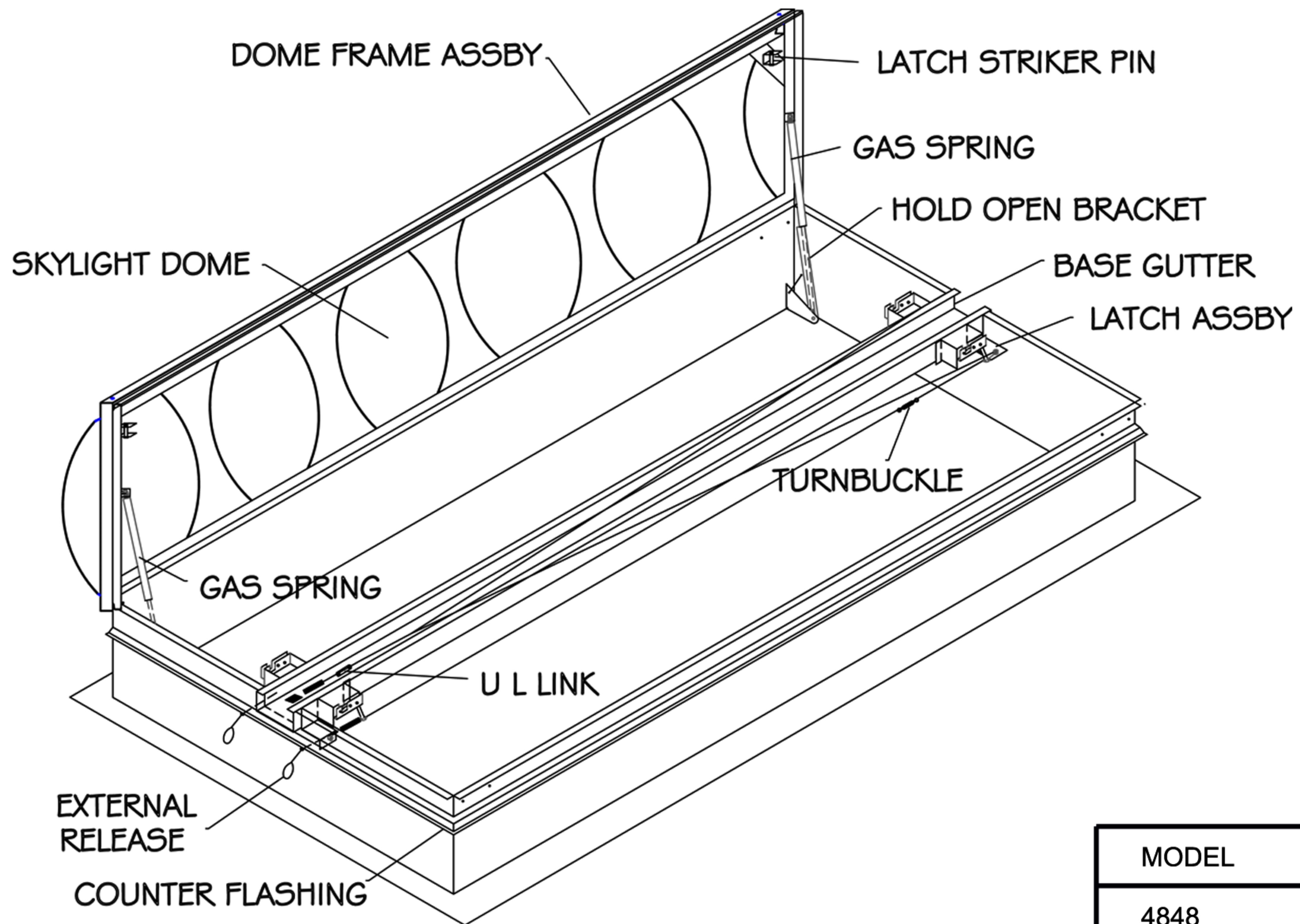
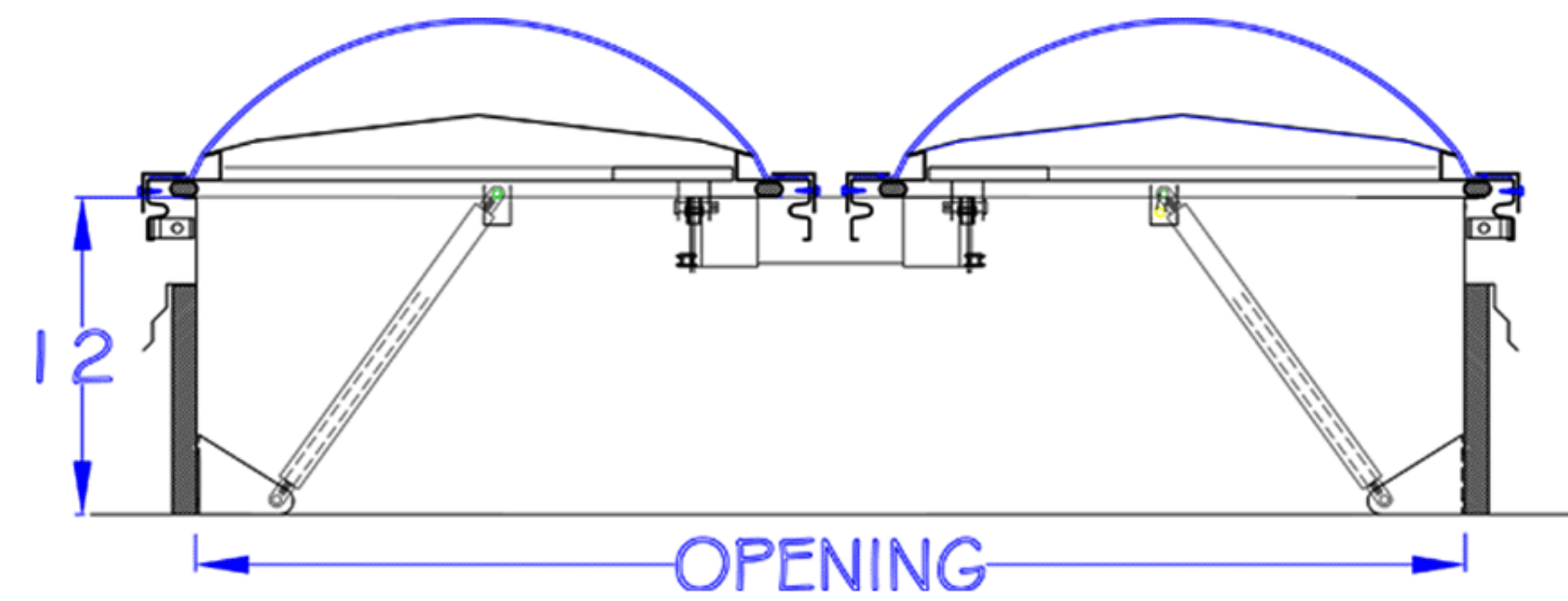
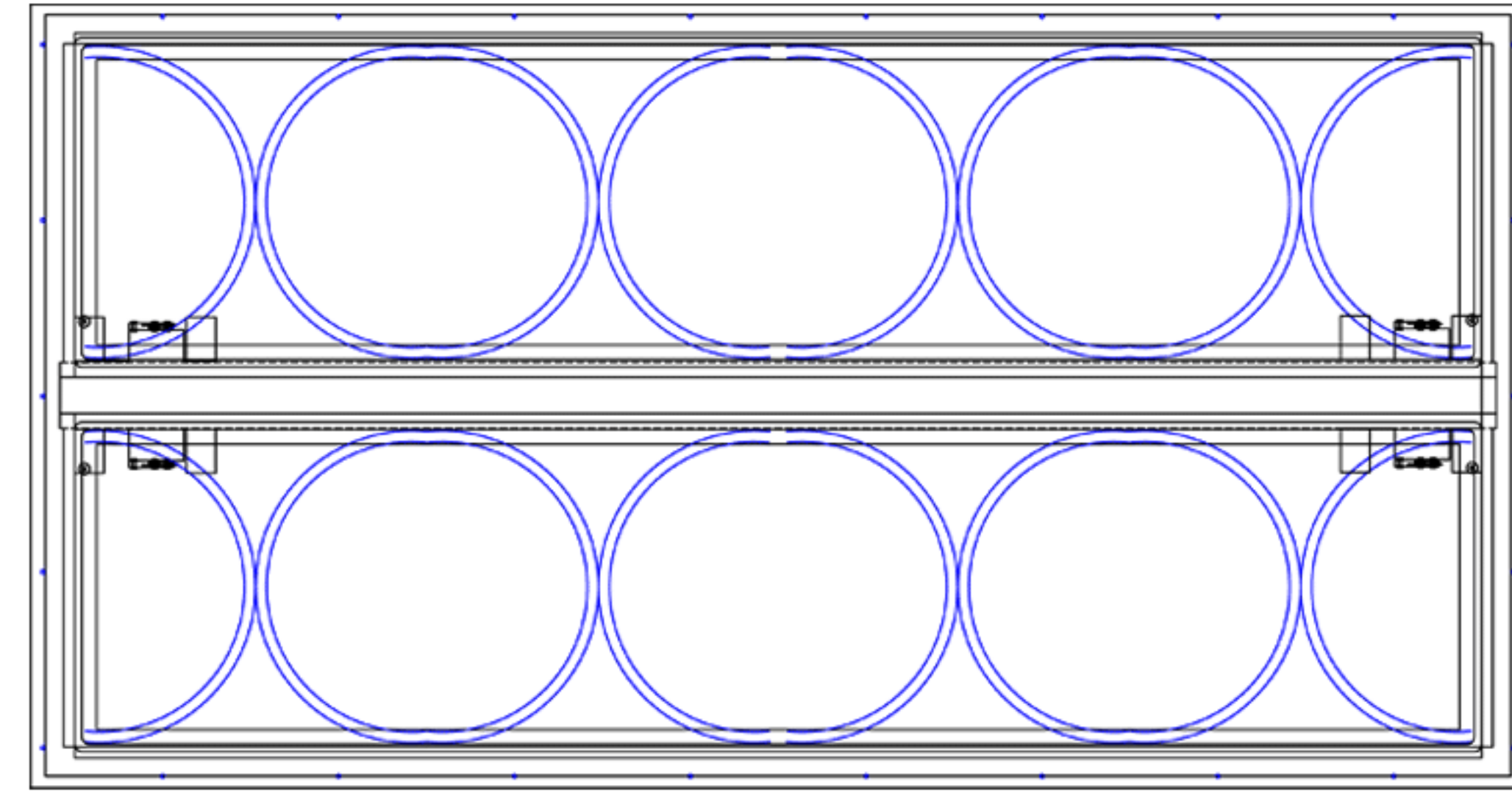

MODEL	SIZE
4848	48" x 48"
4896	48" x 96"
6060	60" x 60"
6072	60" x 72"
6096	60" x 96"



R&S Manufacturing and Sales
 www.RnSales.com
 sales@RnSales.com
 805-375-3980 Fax 805-375-3981

CUSTOMER

QUANTITY

JOB NAME

MODEL

ARCHITECT

DATE

UL LISTED - DOUBLE DOME

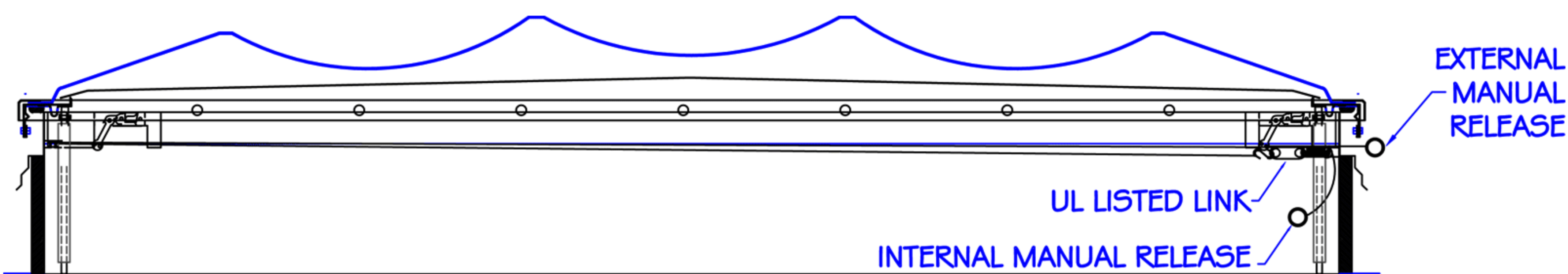
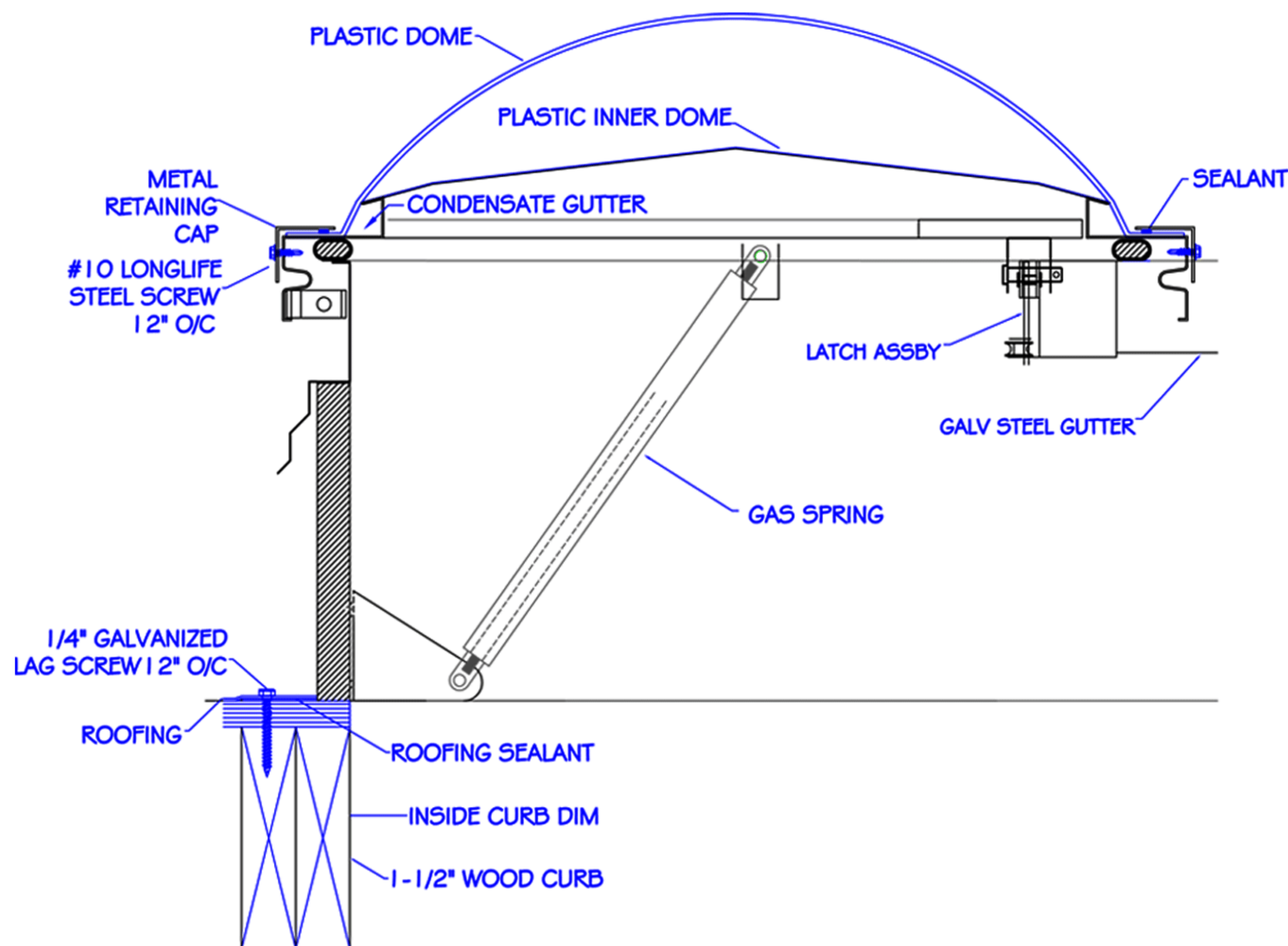
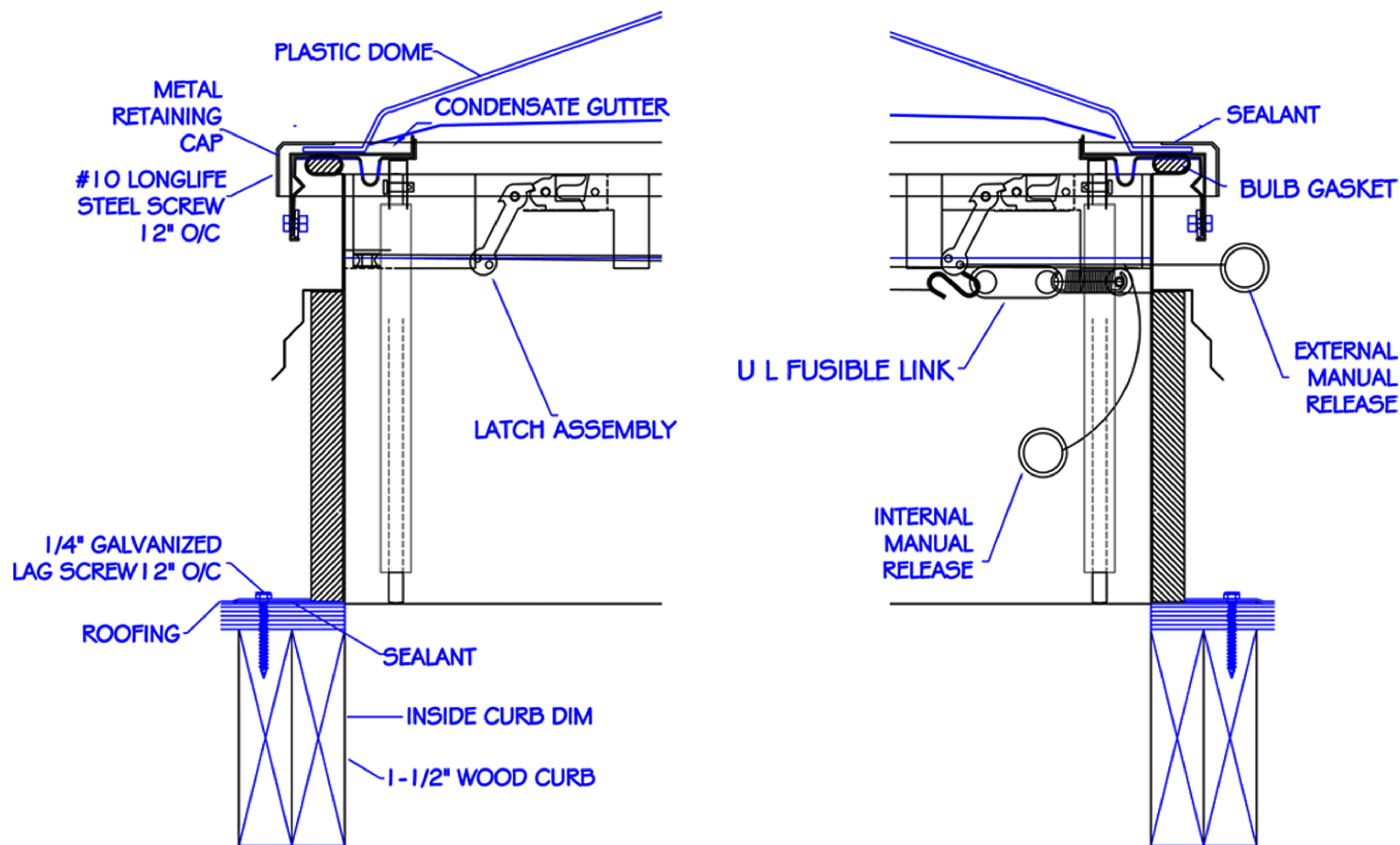

MODEL	SIZE
4848	48" x 48"
4896	48" x 96"
6060	60" x 60"
6072	60" x 72"
6096	60" x 96"



R&S Manufacturing and Sales
 www.RnSales.com
 sales@RnSales.com
 805-375-3980 Fax 805-375-3981

CUSTOMER	QUANTITY
JOB NAME	MODEL
ARCHITECT	DATE

UL LISTED - DOUBLE DOME

BASE OPTIONS

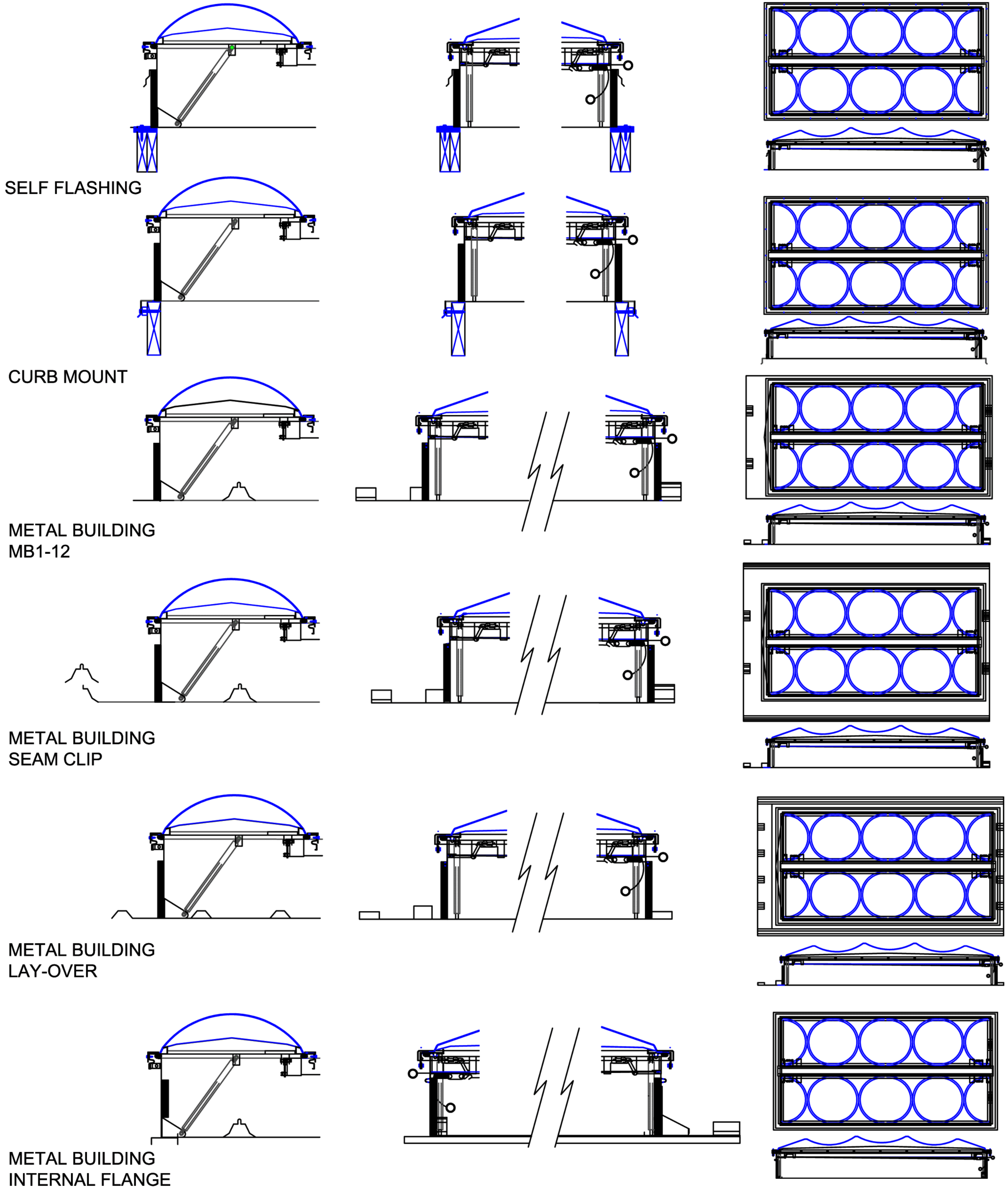

R&S Manufacturing and Sales
 www.RnSales.com
 sales@RnSales.com
 805-375-3980 Fax 805-375-3981

CUSTOMER	QUANTITY
JOB NAME	MODEL
ARCHITECT	DATE