



# STATIONARY LOUVER FILTER RACK

formed aluminum or steel to match louver

Model:  
**SLFR-X**

### FRAME CONSTRUCTION (X)

- 0.040" Aluminum (A)
- 20 GA Galvanized Steel (S)

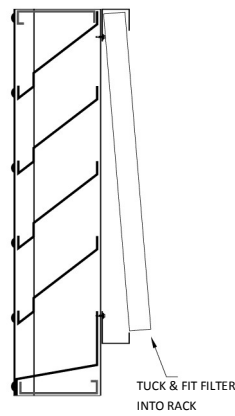
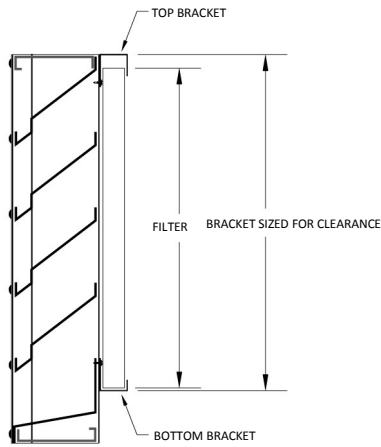

### LOUVER SECTIONS SHOWN WITH FILTER RACK FRAMES ATTACHED

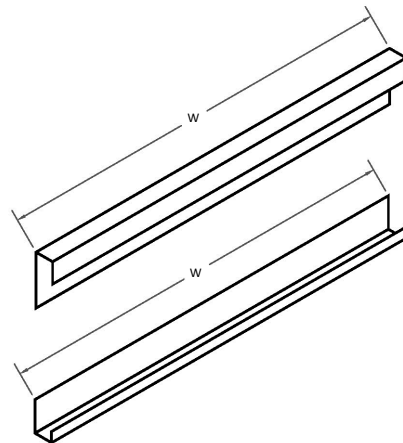
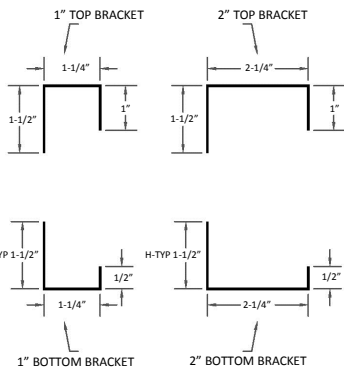
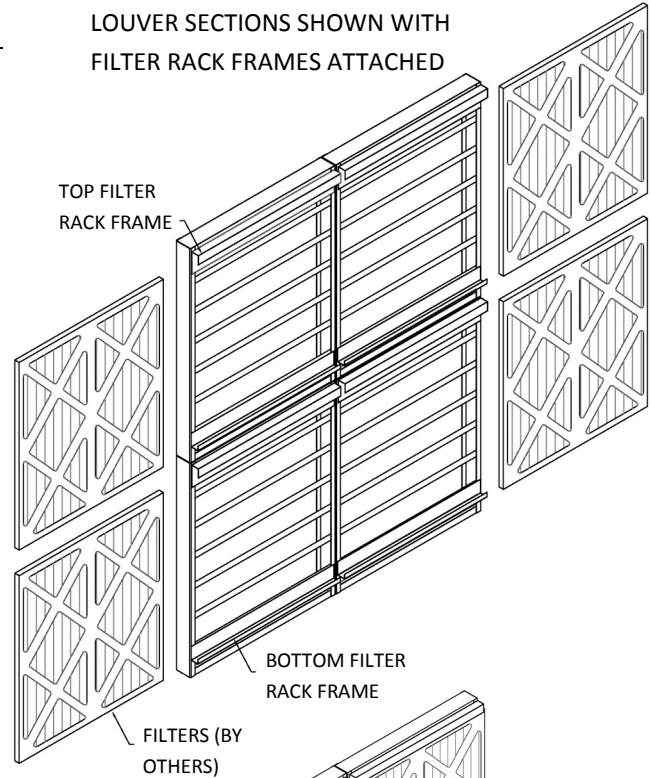

### FILTERS FITTED INTO FRAMES

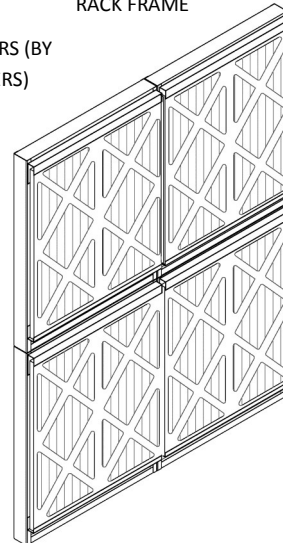

TAG	QTY	FILTER DEPTH 1" OR 2"	WIDTH "W"	MATERIAL—"A" OR "S"	SPECIAL HEIGHT "H" BOTTOM BRACKET

Customer

Job Name

Architect

Model

Date

