



STATIONARY LOUVER

formed aluminum with drainable blade

Model:
FA-60337

CONSTRUCTION

- **FRAME:** 6" deep channel, 0.080" 5052 H32 aluminum with downspouts
- **BLADES:** 6" deep, 37.5° angle, 4-1/4" on center, 0.080" 5052 H32 aluminum with drain gutters
- **SCREEN:** 1/2" Mesh x 0.063" aluminum bird screen when indicated
- **FINISH:** Mill or custom color when indicated
- Riveted and/or welded with drip lip, jamb, and sill flanges
- Minimum Panel Size: 12" x 12", Maximum Panel Size: 96" x 96"
- Undersized 1/2" in A & B dimensions providing 1/4" perimeter clearance
- Approximate shipping weight is: 6 lbs. per square foot
- Louvers larger than max listed require field assembly of smaller sections

FEATURES

- Free Area 56.8%, Water Penetration 0.01oz at 999 FPM free area velocity, Pressure Drop 0.16 in wg at 999 FPM and 8,222 SCFM
- Recycled content 5.3% Post-Consumer, 35.3% Pre-Consumer, 23.0% combined by weight per LEED reference guide

OPTIONS

- Finish options: – Baked polyester – Kynar – Anodized
- Filter rack with applicable filters
- Security bars
- Insect screen (bird screen is standard)
- Hinged frame
- Rivet concealment caps
- Welded construction (high wind loads)
- Stainless steel construction

FRAME CONSTRUCTION (X)

- Metal Building Flange Frame (MB)
- Standard Channel Frame (C)
- Flange Frame (F)

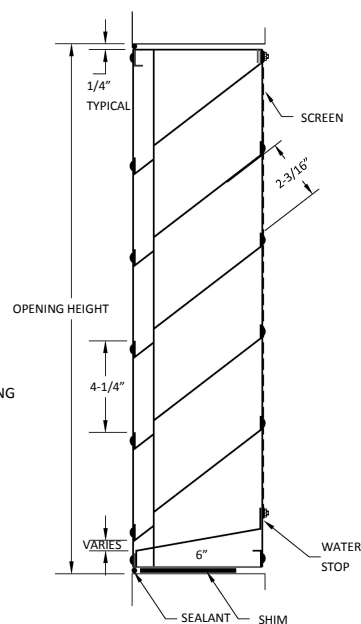
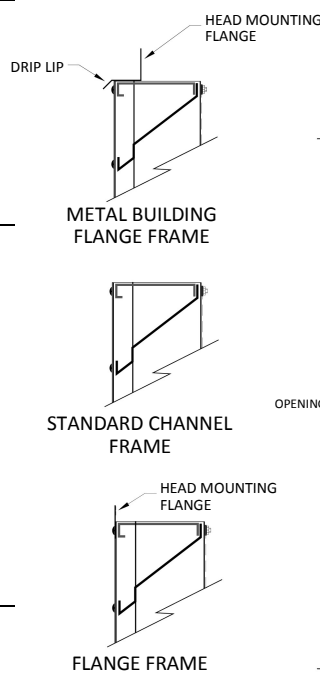
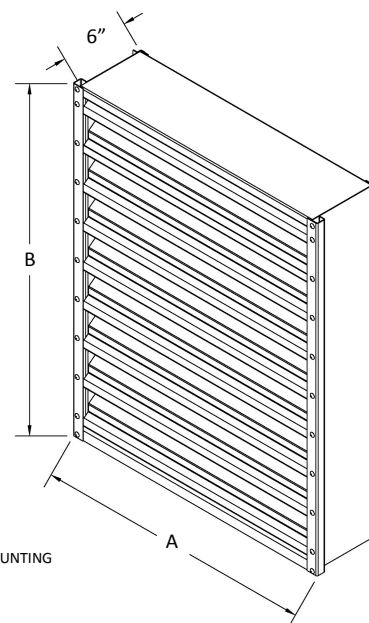

TAG	QTY	WIDTH "A"	HEIGHT "B"	FRAME	FINISH	OPTIONS

Customer

Job Name _____ Model _____

Architect _____ Date _____



PERFORMANCE RATINGS

stationary drainable blade louver (fa-60337)

Airflow Resistance (Standard Air—.075 lb/ft³)

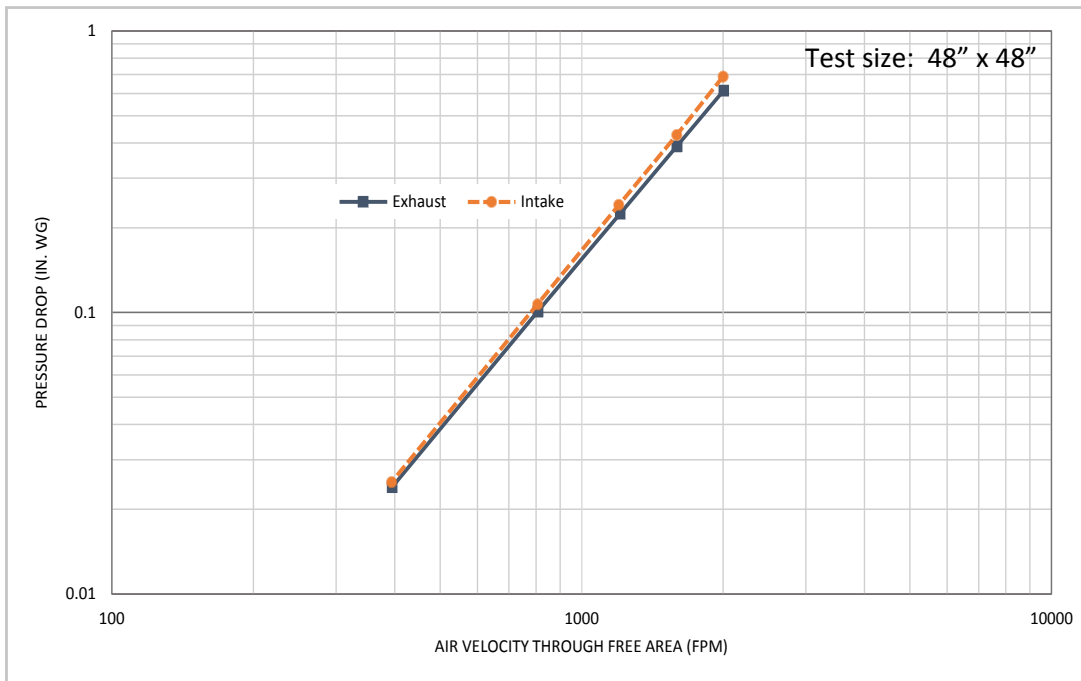

Water Penetration

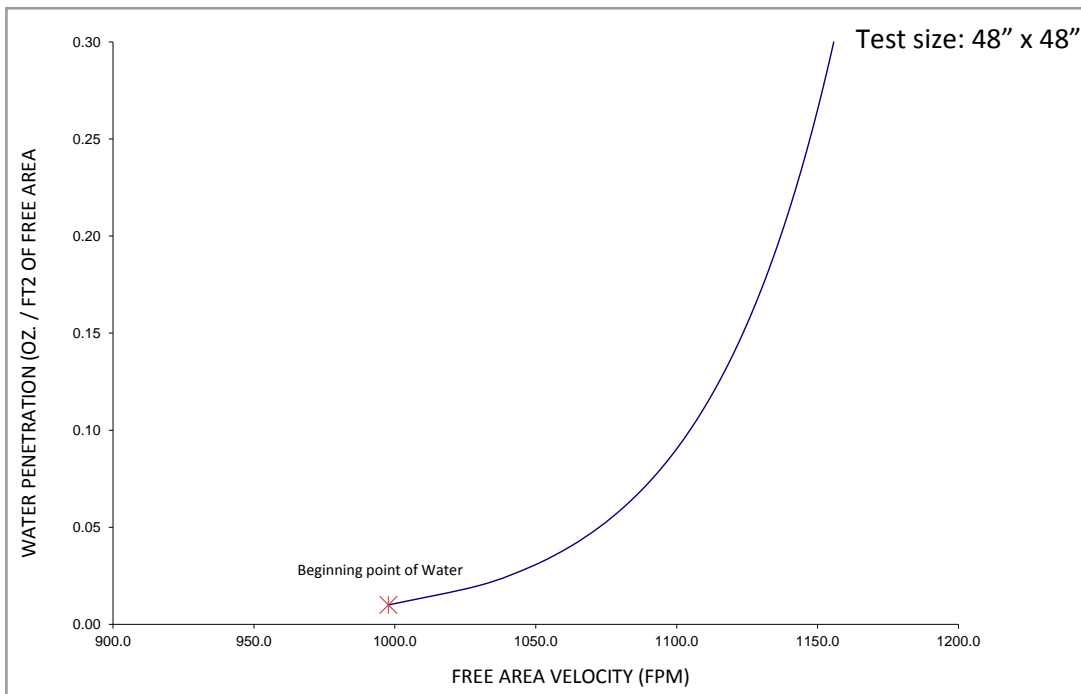

PERFORMANCE RATINGS

stationary drainable blade louver (fg-60337)

Free Area Chart (Square Feet)

		LOUVER WIDTH - INCHES														
		FA60377	12	18	24	30	36	42	48	54	60	66	72	78	84	90
LOUVER HEIGHT - INCHES	12	0.31	0.49	0.67	0.86	1.04	1.23	1.41	1.59	1.78	1.96	2.15	2.33	2.52	2.70	2.88
	18	0.59	0.95	1.31	1.67	2.03	2.39	2.74	3.10	3.46	3.82	4.18	4.54	4.89	5.25	5.61
	24	0.81	1.30	1.78	2.27	2.76	3.25	3.74	4.23	4.71	5.20	5.69	6.18	6.67	7.15	7.64
	30	1.12	1.80	2.48	3.16	3.84	4.51	5.19	5.87	6.55	7.23	7.90	8.58	9.26	9.94	10.62
	36	1.44	2.31	3.17	4.04	4.91	5.78	6.64	7.51	8.38	9.25	10.12	10.98	11.85	12.72	13.59
	42	1.65	2.65	3.65	4.65	5.64	6.64	7.64	8.64	9.63	10.63	11.63	12.63	13.62	14.62	15.62
	48	1.97	3.15	4.34	5.53	6.72	7.90	9.09	10.28	11.47	12.65	13.84	15.03	16.22	17.40	18.59
	54	2.18	3.50	4.82	6.13	7.45	8.77	10.09	11.40	12.72	14.04	15.35	16.67	17.99	19.31	20.62
	60	2.50	4.00	5.51	7.02	8.52	10.03	11.54	13.05	14.55	16.06	17.57	19.08	20.58	22.09	23.60
	66	2.71	4.35	5.99	7.62	9.26	10.90	12.54	14.17	15.81	17.45	19.09	20.72	22.36	24.00	25.64
	72	3.03	4.85	6.68	8.51	10.33	12.16	13.99	15.81	17.64	19.47	21.29	23.12	24.95	26.77	28.60
	78	3.34	5.36	7.37	9.39	11.41	13.42	15.44	17.46	19.47	21.49	23.51	25.52	27.54	29.56	31.57
	84	3.56	5.70	7.85	9.99	12.14	14.29	16.43	18.58	20.73	22.87	25.02	27.17	29.31	31.46	33.60
	90	3.87	6.21	8.54	10.88	13.21	15.55	17.89	20.22	22.56	24.90	27.23	29.57	31.90	34.24	36.58
	96	4.08	6.55	9.02	11.48	13.95	16.41	18.88	21.35	23.81	26.28	28.74	31.21	33.68	36.14	38.61

Suggested Specification

Furnish and install louvers as hereafter specified where shown on plans or as described in schedules. Louvers shall be stationary drainable type entirely contained within a 6" frame. Louvers shall include a drain gutter in each blade and downspouts in jambs and mullions. Louver components (heads, jambs, sills, blades and mullions) shall be factory assembled by the louver manufacturer. Louver sizes too large for shipping shall be built up by the contractor from factory assembled louver sections to provide overall sizes required. Louver design shall limit span between visible mullions to 8 feet and shall incorporate structural supports required to withstand a wind load of 20 pounds per square foot equivalent of a 90 MPH wind. (Specifier may substitute any loading required).

Louvers shall be R&S Model FA-60337 with construction as follows:

FRAME: 0.080" 5052 H32 aluminum

BLADES: 0.080" 5052 H32 aluminum positioned at 37-1/2 degrees on 3-3/8" centers

SCREEN: 1/2" Mesh x 0.063" aluminum bird screen

FINISH: Select finish from baked polyester (powder coat), Kynar, anodized, or mill



TYPICAL INSTALLATION DETAILS

stationary drainable blade louver (fa-60337)

Masonry Wall

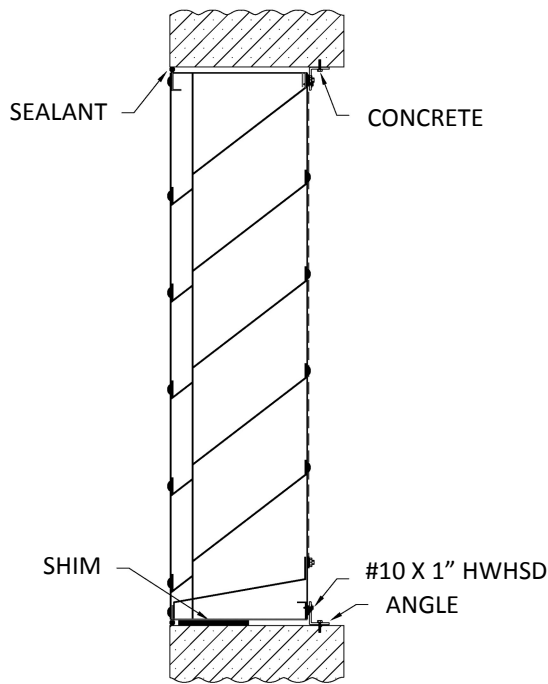

Flange Mount

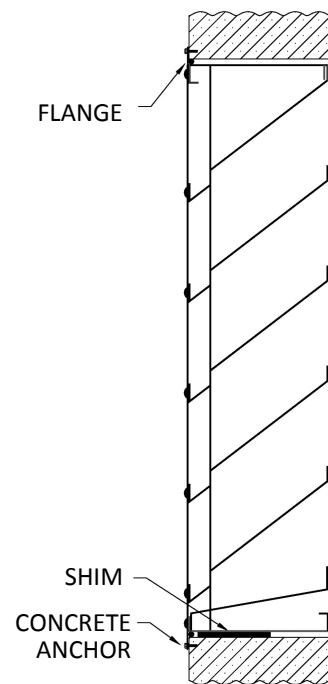

Metal Building Wall

