

GRAVITY RELIEF-INTAKE VENTILATOR

MODEL ST

SPECIFICATIONS:

- FOR GRAVITY RELIEF OR INTAKE VENTILATION
- MILL FINISH GALVANIZED CONSTRUCTION
- WEATHERPROOF AND STORMPROOF UNDER NORMAL OPERATING CONDITIONS
- THROAT SIZES 12" TO 96"
- 1/2" MESH 19 GAUGE GALVANIZED BIRDSCREEN

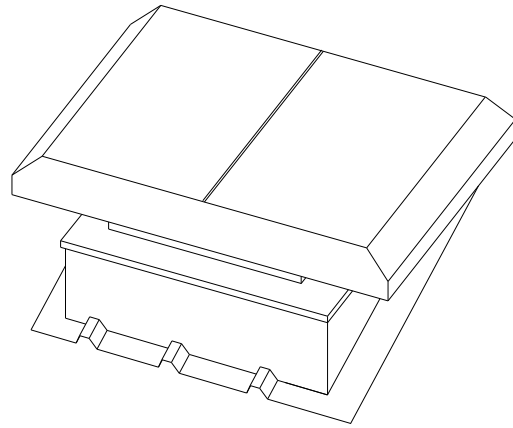

OPTIONS:

- ALUMINUM CONSTRUCTION
- INTEGRAL METAL BUILDING BASES
- CURB MOUNT BASE
- BACKDRAFT DAMPERS
- AIR DRY ENAMEL OR POWDER COAT FINISH

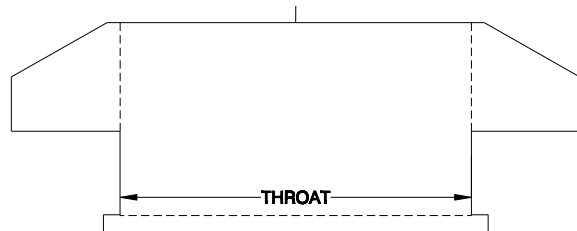

Velocity Ratings (Feet per Minute)

Static Pressure Drop (Inches Water Column)

VELOCITY (FPM)	300	400	500	600	700	800	900	1,000	1,100	1,200	1,300	1,400	1,500
INTAKE	0.010	0.017	0.027	0.038									
EXHAUST	0.014	0.025	0.039	0.056	0.077	0.100	0.127	0.156	0.189	0.225	0.264	0.306	0.352

QUANTITY	MODEL	METAL BUILDING CURB - ROOF PITCH	PANEL MFG.	PANEL MODEL	SLOPE/RIDGE

Project	Contractor
Location	Approved By
Date	Date Approved



R&S MANUFACTURING AND SALES COMPANY
 www.RnSsales.com sales@RnSsales.com
 PHONE 800-423-1619 or 805-375-3980 FAX 805-375-3981