

### CONSTRUCTION

- Wind bands and end caps are 22 or 26 GA steel, depending on vent size
- Internal components and curb constructed of 22, 18, or 14 GA steel
- Aluminum pop rivet fasteners
- Heavy duty banded wood crate

### DESIGN

- 9", 12", 18", 24" or 36" throat size in 10' lengths
- 14 GA steel skirts extend to create curb cap for mounting
- Continuous drainage slots along base of wind band
- SMP off-white pre-finished external sheeting
- 1/2" mesh galvanized bird screen
- Hand-operated damper with 15' chain and chain stay
- Optional custom finish to match most metal building colors

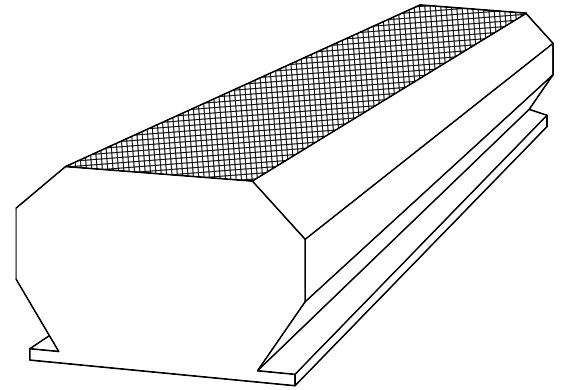

### OPTIONS (ADDITIONAL COSTS MAY APPLY)

- Finish options (select):  Mill finish  Baked polyester  Kynar
- Alternate construction (select):  Aluminum  Stainless steel
- 18 x 16 mesh insect screen:  Galvanized  Aluminum  Stainless steel
- Pneumatic or electric actuator for automatic damper operation (up to five units)
- Wall mount operator kit—hand winch, turnbuckle, pulleys, wire rope, fasteners
- Additional chain for high roof elevation
- No damper assembly (always open)
- High wind tolerance—braces and higher gauge construction
- Curb mount kit
- Knocked-down vents—consolidates deck/container space

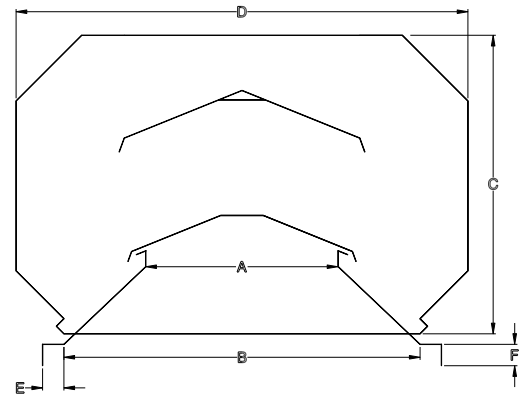

### CFM CAPACITIES

CFM CAPACITIES BASED ON 5 MPH WIND AND FRESH AIR INTAKE AREA OF 1-1/2 TIMES VENTILATOR OPEN AREA

MODEL	RV9	RV9	RV9	RV12	RV12	RV12	RV18	RV18	RV18	RV24	RV24	RV24	RV36	RV36	RV36
HEIGHT	10'	20'	30'	10'	20'	30'	10'	20'	30'	10'	20'	30'	10'	20'	30'
TEMP DIFF 10	1568	1814	2003	2091	2419	2671	3136	3628	4006	4182	4383	5342	6272	7256	8012
TEMP DIFF 20	1814	2162	4929	2419	2883	3229	3628	4324	4858	4838	5766	6438	7256	8648	9716
TEMP DIFF 30	2003	2429	2757	2671	3239	3675	4006	4858	5514	5342	6478	7350	8012	9716	11028

height = vertical distance from vent opening to vertical centerline intake opening

temperature differential = stack height x 0.6 degrees/foot

### SCHEDULE

MODEL	DIM A	DIM B	DIM C	DIM D	DIM E	DIM F	FINISH COLOR	QTY
RV-9	9"	15 1/2"	14"	21 1/4"	2"	2"		
RV-12	12"	20 3/4"	18 1/8"	28 1/4"	2"	2"		
RV-18	18"	31 1/2"	28 1/2"	41"	4"	4"		
RV-24	24"	44 1/4"	37 1/2"	54 1/4"	4"	4"		
RV-36	36"	61 1/4"	51 1/2"	76 1/3"	6"	6"		

Customer \_\_\_\_\_

Date \_\_\_\_\_

Job Name \_\_\_\_\_

Architect \_\_\_\_\_

