

# FLOATING METAL BUILDING ROOF CURB SYSTEM

## MODEL MB3-7FC & MB4-8FC

### SPECIFICATIONS:

18 GAUGE ALUMINIZED STEEL OUTER CURB  
8" MIN HEIGHT & 6" LARGER THAN INNER CURB

14 GA STEEL INNER STRUCTURAL CURB  
10" MINIMUM HEIGHT

PITCHED TO PROVIDE A LEVEL TOP SURFACE WHERE SPECIFIED

1-1/2" WIDE TOP FLANGES

ALL WELDED CONSTRUCTION  
CORNERS MITERED AND WELDED

UPSLOPE FLANGE WITH "UNDER" CONTOURS AND A WATER DIVERTER

DOWNSLOPE WITH "OVER" CONTOURS

COUNTER FLASHING FOR INNER CURB

1" RIGID R7.2 INSULATION (MB3-7 ONLY)

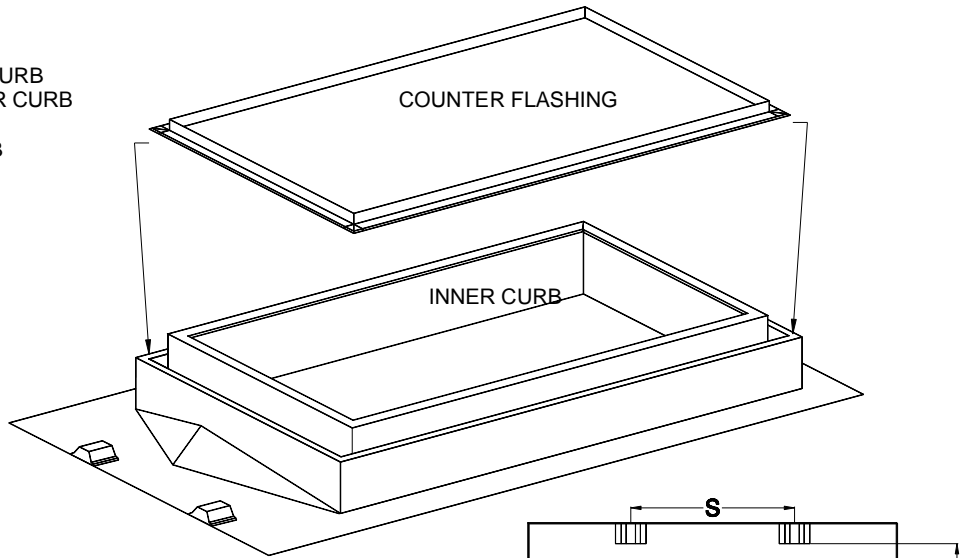

### OPTIONS:

- 14 GAUGE ALUMINIZED STEEL
- 16 GAUGE ALUMINIZED STEEL
- 0.080" ALUMINUM

#### POWDER COAT FINISH -

- WHITE
- CUSTOM COLOR

SPECIAL HEIGHT

DAMPER SHELF/DUCT SUPPORTS

INSIDE OR OUTSIDE INSULATION LINER

SPECIAL RIB PLACEMENT

#### WIDE FLANGES

- UPSLOPE
- SIDE
- DOWNSLOPE

TOP COVER

TOP FLANGE BROKEN OUT

DIVERTER IN LIEU OF CRICKET

SUB FRAMING

2-1/2" WIDE MASTIC

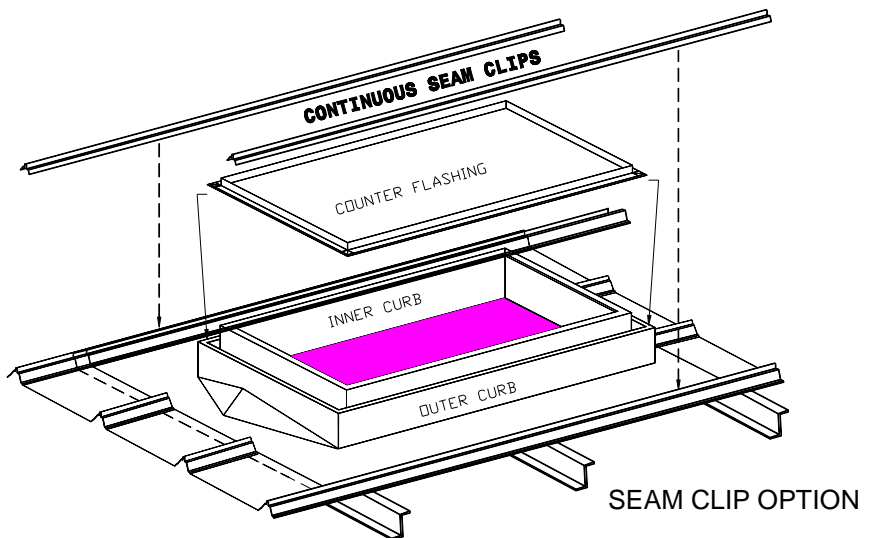
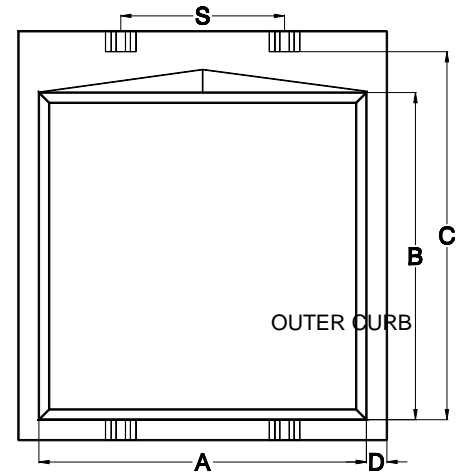
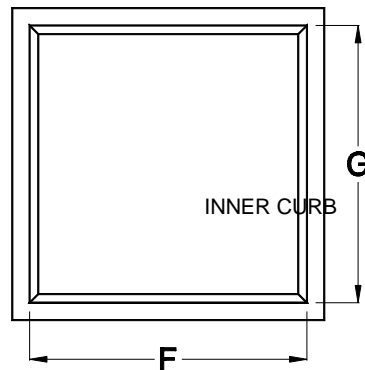

**Project**

**Location**

**Date**

**Contractor**

**Approved By**

**Date Approved**

# INSTALLATION INSTRUCTIONS

# MODEL MB3-7FC & MB4-8FC

1. On a fully sheeted roof, mark centerline of roof opening.
2. Use centerline of major rib as a guide and lay out roof opening to match the curb A, C, & D dimensions.
3. Cut roof opening per building manufacturer's recommendations. Slit upslope edges of rough opening (D) for side flange clearance at transition point.
4. Install structural support framing for inner curb with equipment loads and outer flashing curb. Keep inside dimension clear. A minimum of two parallel curb walls should be supported. Avoid cantilever sections in excess of 12".
5. Apply mastic or sealant tape at points where curb meets roof panel. Apply to roof panel at curb side, and downslope flanges. Apply to curb upslope flange. Use only accessories as recommended by the building manufacturer.
6. Press curb into place on the roof panel. Upslope flange goes under roof panel; sides and downslope over roof panel.
7. Fasten the inner curb to support structure through curb flange and roof panel using fasteners compatible with the roof system. Use a minimum of four fasteners per side on maximum 4" centers. Miter the corners of the counter-flashing to insure weather tightness. Install counter flashing to inner curb and seal as shown at right.
8. Check tightness of fasteners and general integrity of installation. Caulk perimeter edge of curb flanges to roof panel.

